

bosal

МАГАЗИН

Инструкция по монтажу
тягово-сцепного устройства
шарового типа **1428 А**
для автомобилей

Renault Fluence Lim

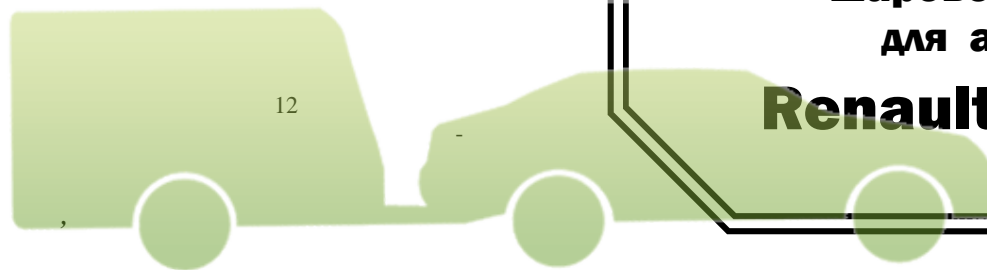

ФАРКОПОВ

+7 (495) 6-693-693

www.magfarkop.ru
magfarkop@yandex.ru



462800,

т. (35363) 7-05-06
ф. (35363) 7-13-20
(495) 785-66-07
www.bosal-autoflex.ru

	03/2010 -...
	1200
	75
	18

« - »:	(8182) 22-48-15
"	8(8442) 98-74-98
"	8(343) 379-39-89, 373-42-73
"	8(343) 26-88-308
"	8(3952) 710-194
"	8(495) 777-54-59
"	8(495)745-79-11
"	8(495) 788-95-97
"	8(495) 720-51-03
"	8(3532) 57-99-85
"	8-905-899-5012
"	8(383) 291-59-60
"	8(831) 279-53-24
"	8(3422) 98-27-20
"	8(342) 220-87-87
"	8-927-002-90-06
"	8(3462) 24-00-44
"	8(3842) 21-14-76
"	8-902-940-4151
"	8(3452) 32-22-12, 41-52-62
"	8-961-213-0278
"	8-917-347-1700
"	8(351) 269-44-75, 900-72-73
"	8(3512) 773-76-91

41.55-2005.

- 1.
- 2.
- 3.
- 4.
- 5.
- 6.
- 7.
- 8.
- 9.
- 10.
- 11.

МАГАЗИН ФАРКОПОВ

+7 (495) 6-693-693

www.magfarkop.ru
magfarkop@yandex.ru

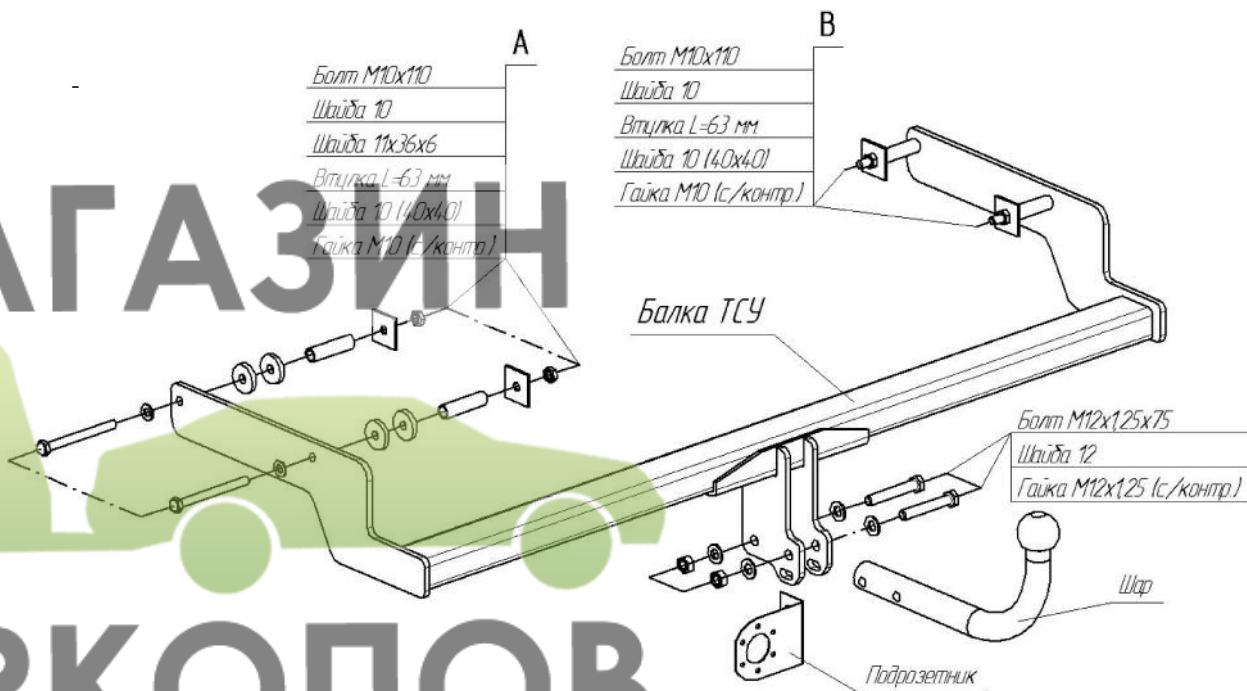

&11 36 6

: 12—79Nm ;

10—46Nm.

1		
2		
3		
4		
5		
6		
7		

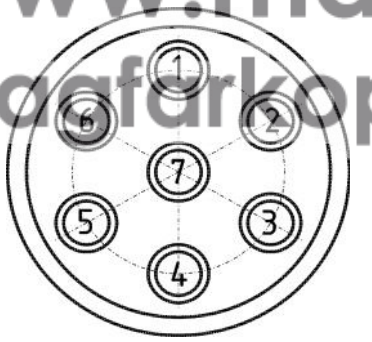

	1	
	1	
	1	

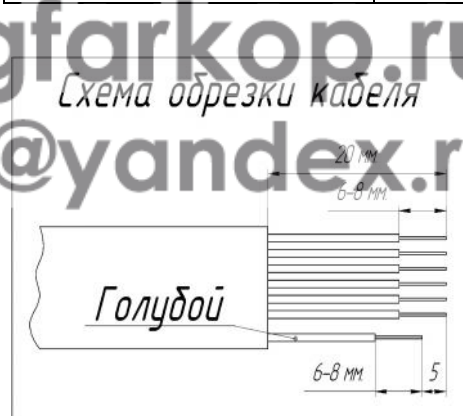

	1	1
&16 1,6 L = 63		4
10 110		4
12 1,25 75		2
10 /		4
12 1,25 /		2
10		4
10 (40 40)		4
12		4
&11 36 6		4
VH 0826		1
		1
		1
		1
		1