

# bosal

# МАГАЗИН

**Инструкция по монтажу  
тягово-сцепного устройства  
шарового типа 2731 А  
для автомобилей  
Renault Clio Symbol,  
Thalia**

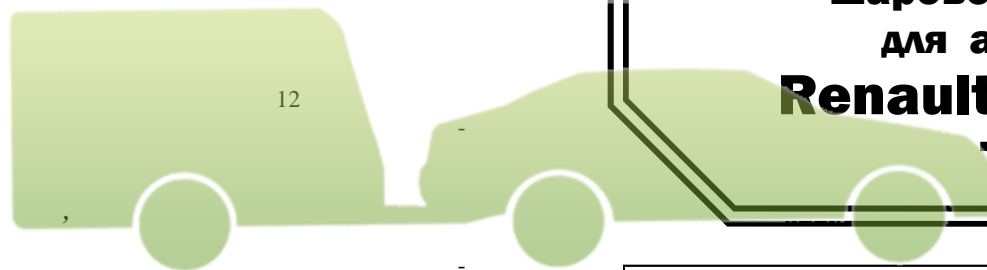

# ФАРКОПОВ

# +7 (495) 6-693-693

	1999 – ...
	1000
	75
	15.5

[www.magfarkop.ru](http://www.magfarkop.ru)  
[magfarkop@yandex.ru](mailto:magfarkop@yandex.ru)



462800,

18  
: (35363) 7-05-06  
/ : (35363) 7-13-20  
(495) 785-66-07  
[www.bosal-autoflex.ru](http://www.bosal-autoflex.ru)

"	"	(8182) 22-48-15
"	"	8(8442) 98-74-98
"	"	8(343) 379-39-89, 373-42-73
"	"	8(343) 26-88-308
"	"	8(3952) 710-194
"	"	8(495) 777-54-59
"	"	8(495) 745-79-11
"	"	8(495) 788-95-97
"	"	8(495) 720-51-03
"	"	8(3532) 57-99-85
"	"	8-905-899-5012
"	"	8(383) 291-59-60
"	"	8(831) 279-53-24
"	"	8(3422) 98-27-20
"	"	8(342) 220-87-87
"	"	8-927-002-90-06
"	"	8(3462) 24-00-44
"	"	8(3842) 21-14-76
"	"	8-902-940-4151
"	"	8(3452) 32-22-12, 41-52-62
"	"	8-961-213-0278
"	"	8-917-347-1700
"	"	8(351) 269-44-75, 900-72-73
"	"	8(3512) 773-76-91

41.55-2005.

# МАГАЗИН ФАРКОПОВ

+7 (495) 6-693-693

www.magfarkop.ru  
magfarkop@yandex.ru

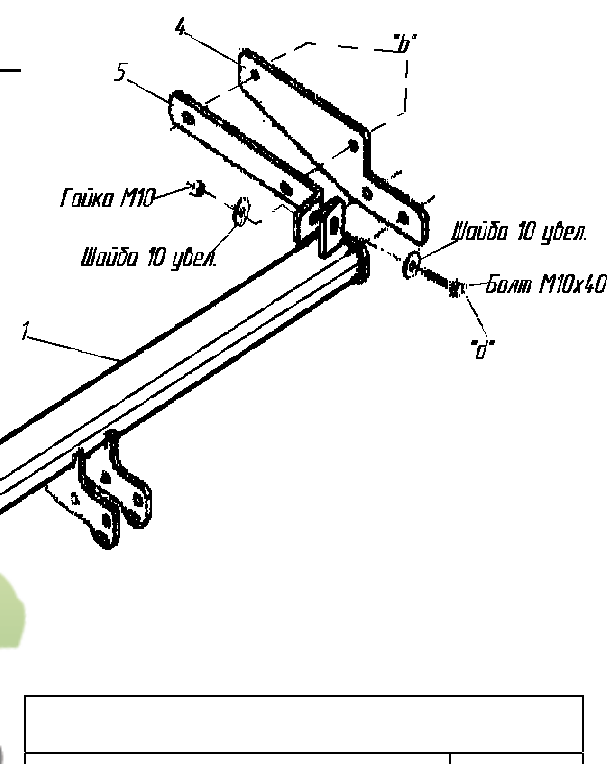

(2,3)  
« » ( )  
2  
3 4  
4,5  
« »  
«d»  
1 1  
3 4  
3 5

1		
2		
3		
4		
5		
6		
7		



	1
	1
	1
	1
	1
	1
	1
	1

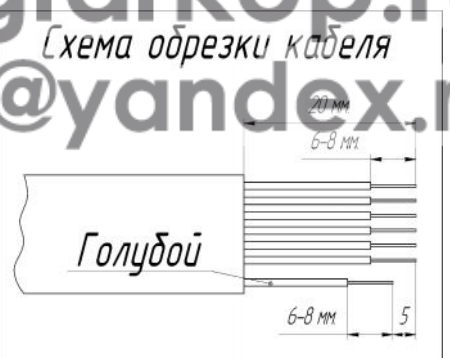

	3
10 /	6
12x1.25 /	2
12 /	2
12 1.25x90	2
10 40	6
12 1.75x40	4
10	4
10	8
12 ( )	2
12	9
VH 0300	1
	2
	1
	1
	1
190	1
	1