

- D** Montage- und Betriebsanleitung
- CZ** Návod k montáži a provozu
- DK** Montage- og driftsvejledning
- E** Instrucciones de montaje y de servicio
- F** Notice de montage et d'utilisation
- FIN** Asennus- ja käyttöohjeet
- GB** Installation and Operating Instructions
- GR** Οδηγίες τοποθέτησης και λειτουργίας
- I** Istruzioni di montaggio e per l'uso
- N** Monterings- og bruksanvisning
- NL** Montage- en gebruikshandleiding
- S** Monterings- och bruksanvisning
- PL** Instrukcja montażu i eksploatacji

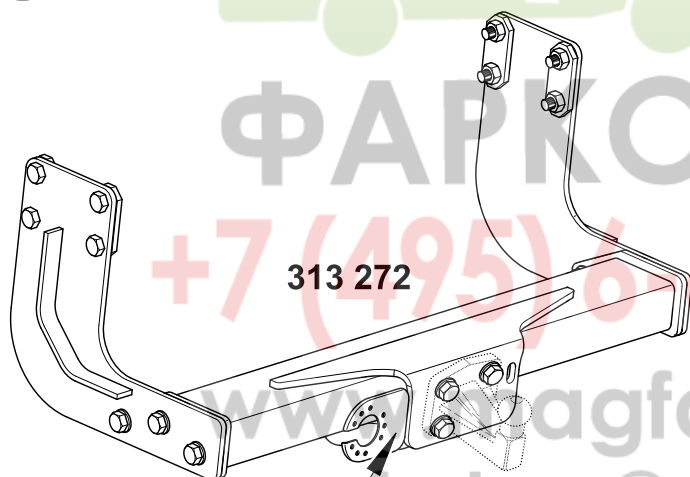

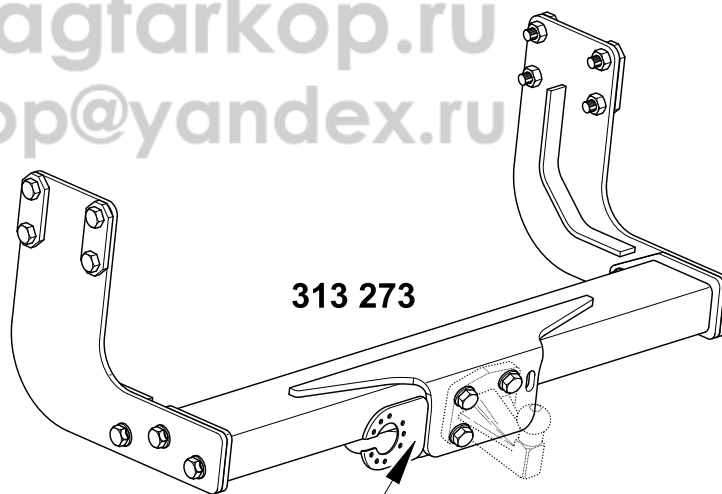







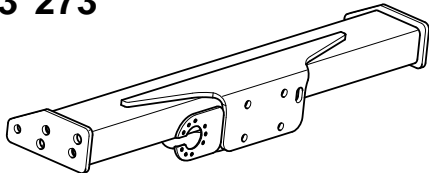
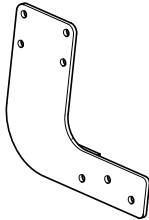
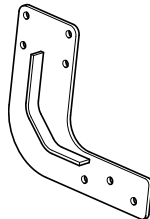

APPROVAL NO:		D-VALUE:	D	kN
TYPE:		VERT. LOAD:	S	kg
PART NO:		COUPLING CLASS:		
WESTFALIA		CHARGE:		



APPROVAL NO:		D-VALUE:	D	kN
TYPE:		VERT. LOAD:	S	kg
PART NO:		COUPLING CLASS:		
WESTFALIA		CHARGE:		

- D** Lieferumfang der Anhängervorrichtung
- CZ** Objem dodání tažného zařízení
- DK** Anhængertrækkets leveringsomfang
- E** Volumen de suministro del enganche
- F** Pièces comprises dans la fourniture de l'attelage
- FIN** Vetokoukun toimituksen sisältö
- GB** Scope of delivery of towing hitch
- GR** Περιεχόμενο του πακέτου της σφαιρικής κεφαλής ζεύξης με στήριγμα
- I** Dotazione del gancio di traino
- N** Leveringsomfang for tilhengerfestet
- NL** Leveringsomvang trekhaak
- S** Dragkrokens leveransspecifikation
- PL** Zakres dostawy haka holowniczego

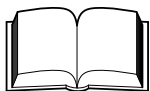
		313 273	
1	1x		
2	1x		
3	1x		
4	4x		
5	8x		M12x1,5x100 (10.9)
6	6x		M12x1,5x40 (8.8)
7	2x		M10x50 (10.9)
8	2x		M10x40 (10.9)
9	10x		13x24x2,5
10	6x		10,5x20x2
11	12x		M12x1,5 (10)
12	2x		M10 (10)
13	1x		

313 272

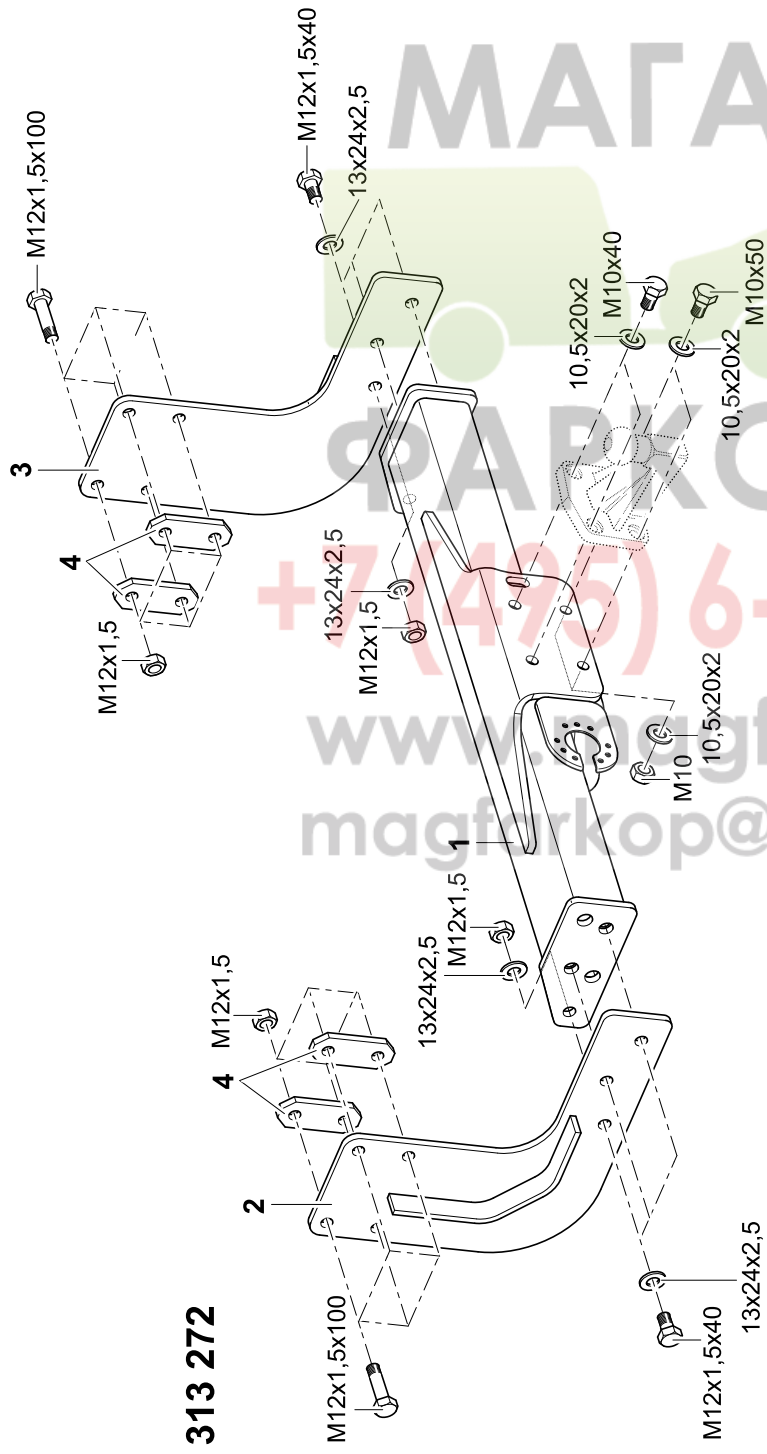

313 273

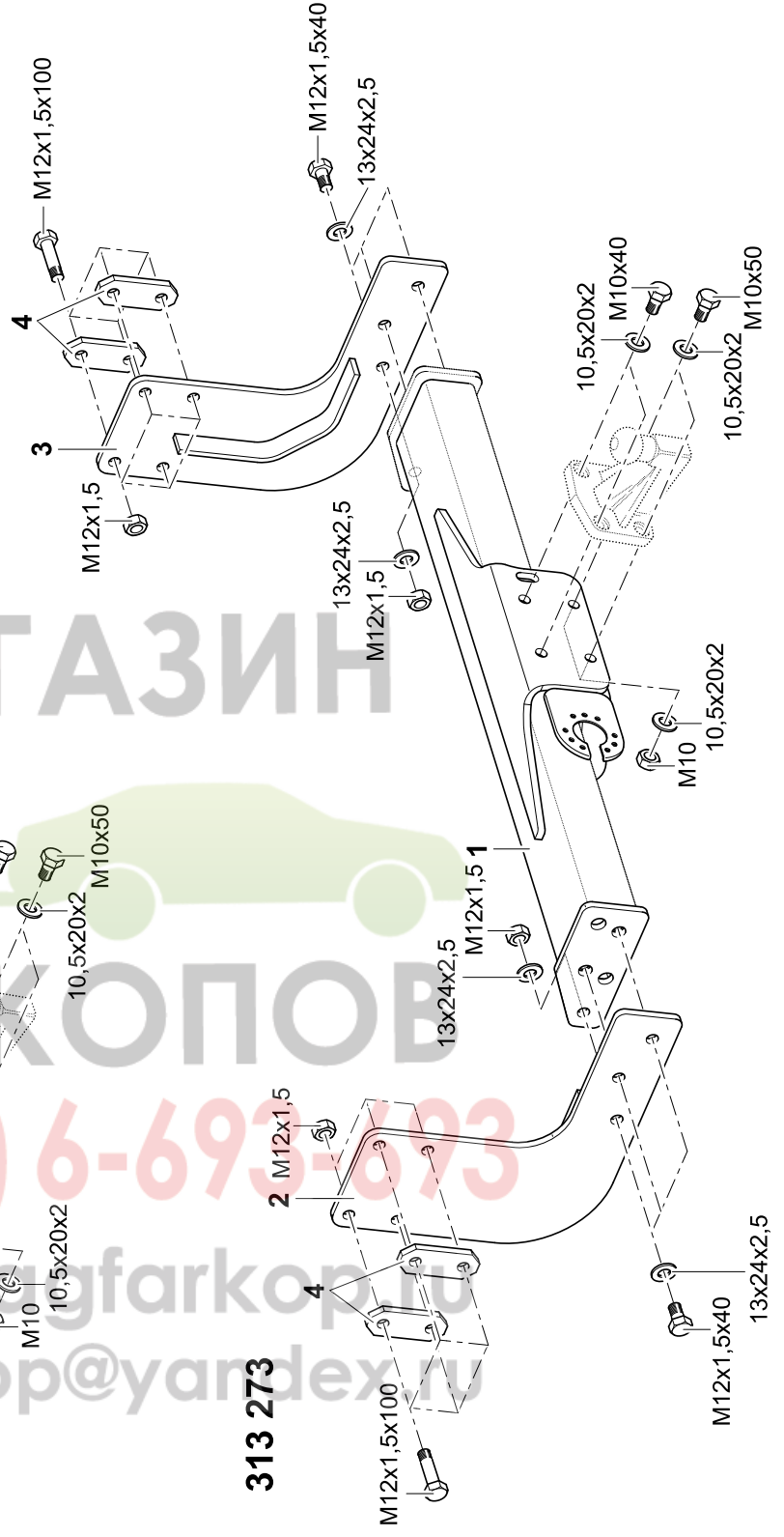

- D -** Der Freiraum nach Anhang VII, Abbildung 30 der Richtlinie 94/20/EG ist zu gewährleisten.
- DK -** Frirommet skal overholdes iht. bilag VII, fig. 30 i direktiv 94/20/EF.
- CZ -** Volný prostor ve smyslu Přílohy VII, obr. 30 Směrnice č. 94/20/EG musí být zaručen.
- E -** Debe garantizarse el espacio libre, conforme al anexo VII, figura 30 de la directiva comunitaria CE/94/20.
- F -** La zone de dégagement doit être garantie conformément à l'annexe VII, illustration 30 de la directive 94/20/CE.
- FIN -** Vapaa tila on taattava direktiivin 94/20/EY liitteen VII, kuvan 30 mukaisesti.
- GB -** The clearance specified in appendix VII, diagram 30 of guideline 94/20/EG must be guaranteed.
- GR -** Πρέπει να εξασφαλίζεται ο ελεύθερος χώρος σύμφωνα με το παράρτημα VII, εικόνα 30 της Οδηγίας 94/20/EOK.
- H -** Biztosítani kell a 94/20/EK irányelv szerinti, VII. számú függelék 30. ábrában jelölt szabad teret.
- I -** Deve essere garantito lo spazio libero secondo l'allegato VII, figura 30 della direttiva 94/20/CE.
- N -** Frirommet etter tillegg VII, avbildning 30 i direktiv 94/20/EEC skal overholdes.
- NL -** De tussenruimte conform supplement VII, afbeelding 30 van de richtlijn 94/20/EG moet in acht worden genomen.
- P -** Garantir a zona livre, conforme Anexo VII, gráfico 30 da Norma 94/20/CE.
- PL -** Należy zagwarantować przestrzeń swobodną według załącznika VII, ilustracja 30 wytycznej 94/20/EG.
- S -** Spelrummet enligt bilaga VII, figur 30 i riktlinje 94/20/EG skall garanteras.
- SLO -** Zagotoviti zračnost po priklopu VII, slika 30, smernice 94/20/EG.
- SK -** Volný priestor v zmysle Prílohy VII, obr. 30 Smernice č. 94/20/EG musí byť zaručený.
- TR -** 94/20/EG Yönetmeliði, Ek VII, Resim 30'da belirtilen serbest alan býrakýlmalýdýr.

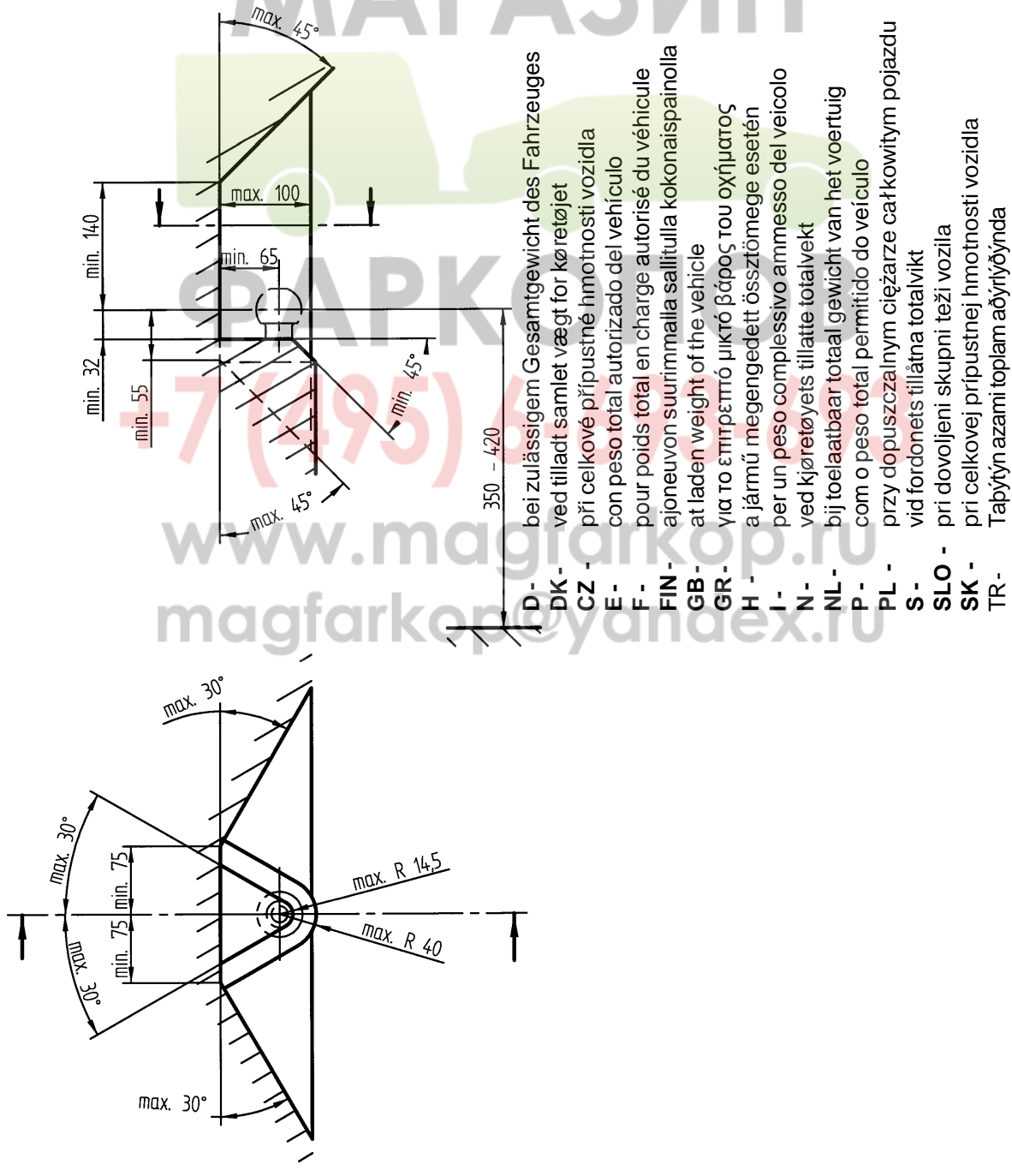

- D** - Der Handhebel Freiraum von Bolzenkupplungen nach Anhang VII, Abbildung 33 der Richtlinie 94/20/EG ist zu gewährleisten.
- DK** - Frirommet for boltkoblingernes håndtag skal overholdes iht. bilag VII, fig. 33 i direktiv 94/20/EF.
- CZ** - Volný prostor ruční páky čepových spojek ve smyslu Přílohy VII, obr. 33 Směrnice č. 94/20/EG musí být zaručen.
- E** - Debe garantizarse el espacio libre para la palanca manual en los enganches por pernos, conforme al anexo VII, figura 33 de la directiva comunitaria CE/94/20.
- F** - La zone de dégagement du levier de l'axe d'attelage doit être garantie conformément à l'annexe VII, illustration 33 de la directive 94/20/CE.
- FIN** - Vetoaisakytkimien käsivivun vapaa tila on taattava direktiivin 94/20/EY liitteen VII, kuvan 33 mukaisesti.
- GB** - The hand lever clearance of bolt couplings specified in appendix VII, diagram 33 of guideline 94/20/EG must be guaranteed.
- GR** - Πρέπει να εξασφαλίζεται ο ελεύθερος χώρος για τον χειρομοχλό συστημάτων ζεύξης με πείρο σύμφωνα με το παράρτημα VII, εικόνα 33 της Οδηγίας 94/20/EOK.
- H** - Biztosítani kell a csapos tengelykapcsolók kézikarjának szabad terét a 94/20/EK irányelv VII. függelékének 33. számú ábrája szerint.
- I** - Per la leva a mano deve essere garantito lo spazio libero dai giunti a pioli secondo l'allegato VII, figura 33 della direttiva 94/20/CE.
- N** - Frirommet for boltkoplingers håndtag etter tillegg VII, avbilding 33 i direktiv 94/20/EEC skal overholdes.
- NL** - De hendeltussenruimte van boutkoppeling volgens supplement VII, afbeelding 33 van de richtlijn 94/20/EG moet in acht worden genomen.
- P** - Garantir as zonas livres para alavancas de acoplamentos por pinos, conforme Anexo VII, gráfico 33 da Norma 94/20/CE.
- PL** - Należy zagwarantować swobodną przestrzeń dźwigni ręcznej sprzęgieł palcowych według załącznika VII, ilustracja 33 wytycznej 94/20/EG .
- S** - Spelrummet för bultkopplingens manöverspak enligt bilaga VII, figur 33 i riktlinje 94/20/EG skall garanteras.
- SLO** - Zagotoviti zračnost ročnega vzvoda sklopk sornikov, po priklopu VII, slika 33 , smernice 94/20/EG.
- SK** - Volný priestor ručnej páky čapových spojek v zmysle Prílohy VII, obr. 33 Smernice č. 94/20/EG musí byť zaručený.
- TR** - Pimli kavramalar için 94/20/EG Yönetmeliði, Ek VII, Resim 33'te belirtilen el kolu serbest alaný býrakýlmalýdır.

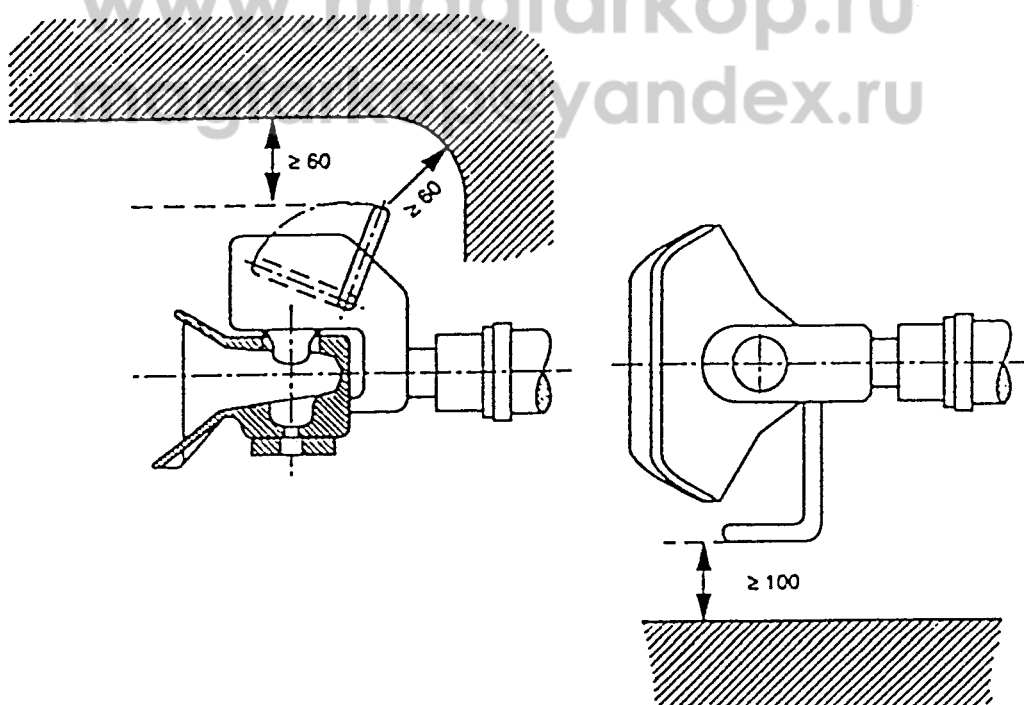

GB Towing hitch Without electrical set

Manufacturer: WESTFALIA-AUTOMOTIVE GmbH

Westfalia order no.: 313 272

313 273

Approval no. as per Guideline 94/20/EC: **e13 00-2235, 2236**
Class: **F** Model: **313 272, 313 273**
Technical data: Maximum D-value: **20,2 kN**
Maximum nose weight: **150 kg**

Area of application:

Vehicle manufacturer: **Daimler Chrysler / VW**
Model: **Sprinter →5,0t (411-524) / Crafter →5,0t, 04/2006→ (50)**
Box-type delivery vans/estate cars

Model designation: Daimler Chrysler: **WDB?????, WDF?????**
VW: **2EC?, 2EKE?, 2FJE?, 2E0**
VW model code UK: **2E, 2F**

This towing device may be fitted with towing hitches (A50-X class, 329059) and bolt couplings (e.g., C50 class) - also in connection with removable plate systems.

The coupling point clearance of a towing hitch or a bolt coupling must be a minimum of 75 mm and a maximum of 154 mm from the rear of the screw-down area. The clearance from the upper mounting points "d" must be a maximum of 19 mm above and 28 mm below.

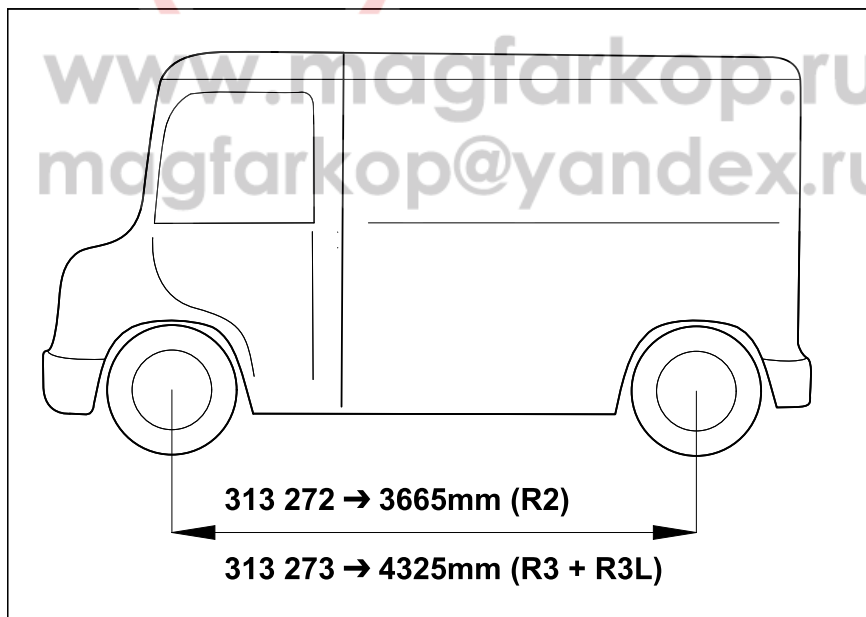

General information:

The **vehicle manufacturer's specifications** regarding trailer load and nose weight are **decisive** for driving, and the values specified for the towing hitch must not be exceeded.

Formula for D-value:
$$\frac{\text{trailer load [kg]} \times \text{vehicle total weight [kg]}}{\text{trailer load [kg]} + \text{vehicle total weight [kg]}} \times \frac{9,81}{1000} = D \text{ [kN]}$$

The towed-vehicle assembly may only be used for towing trailers when fitted with a towing hitch or an automatic bolt coupling and a matching towbar ball receptacle or towbar eye on the trailer. Only trailers which have been approved may be used with a towing hitch.

Any use other than that specified is prohibited. Driving with a trailer must be adapted to the road conditions. The vehicle's handling is affected when a trailer is being towed. Follow the vehicle manufacturer's instructions.

The fixing points specified as standard must be observed.
National guidelines concerning official approval of auxiliaries must be observed.
These installation and operating instructions must be enclosed with the vehicle papers.

Installation instructions:

The towing hitch is a safety component and must only be installed **by qualified personnel**. Any alteration or conversion to the towing hitch is prohibited, and would lead to cancellation of design certification.

Remove insulating compound and underseal from vehicle (if present) in the area of the mating surfaces of the towing hitch. Seal any bare bodywork and bores with anti-corrosive paint.

Operating instructions:

Again tighten all securing bolts of the towing hitch after approx. 1000 trailer km, observing specified tightening torques.

The towing hitch must be kept clean and greased. However, if a stabilisation device, e.g. Westfalia "SSK", is used, the towing hitch must be free from grease. Follow the instructions in the relevant operating instructions.

As soon as the towing hitch diameter is 49.0 mm or less at any point, it must no longer be used for safety reasons.

After the towing hitch is fitted, the empty weight of the vehicle increases by 18 kg.

313 272

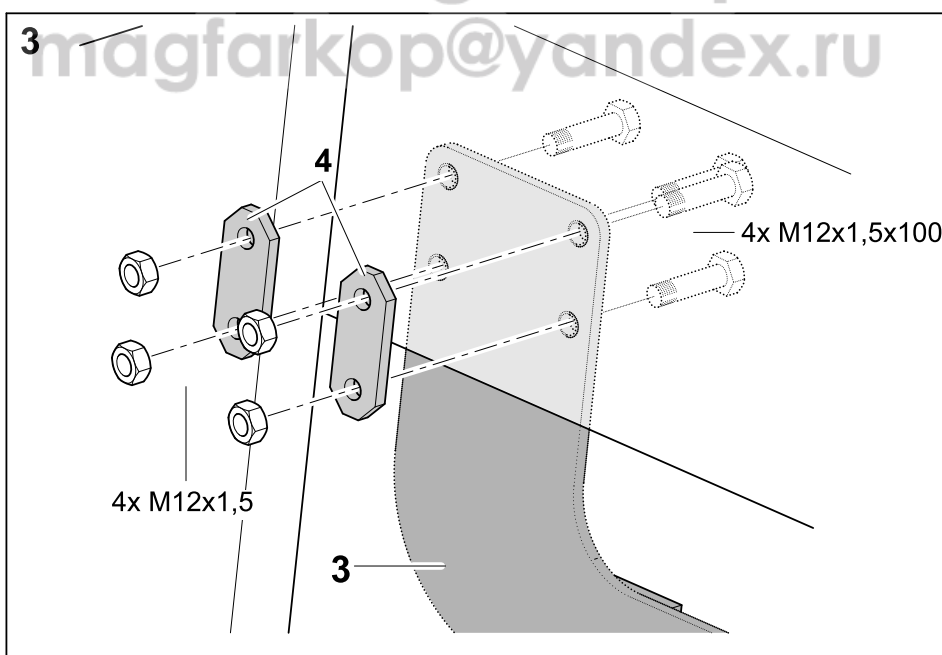
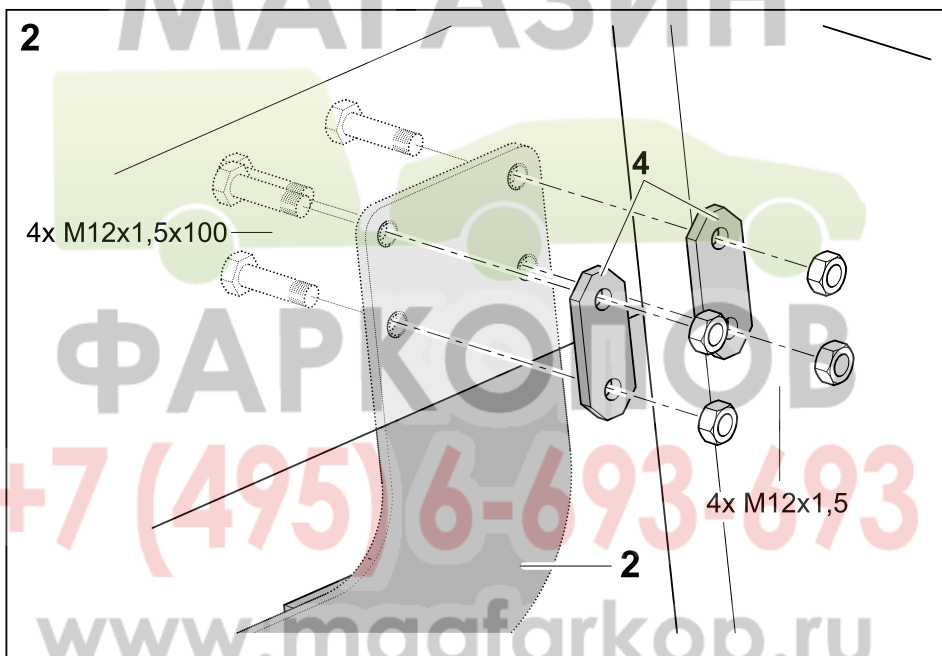
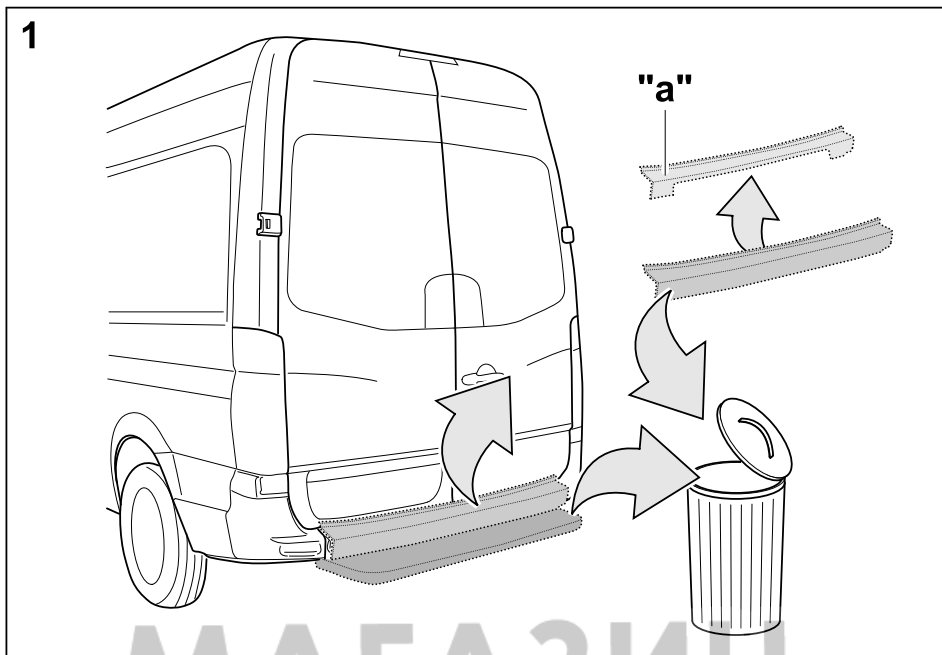

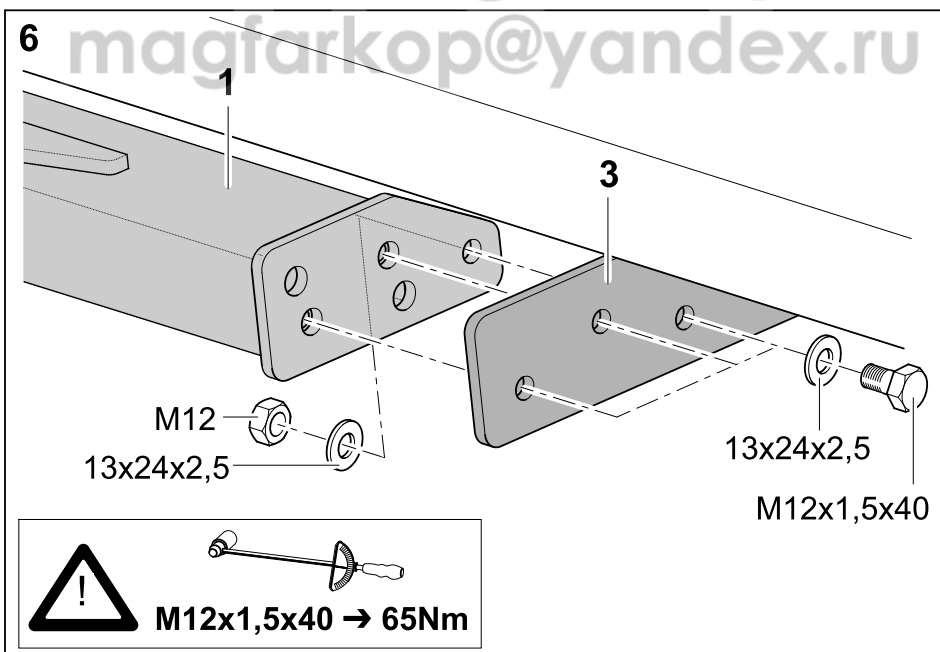
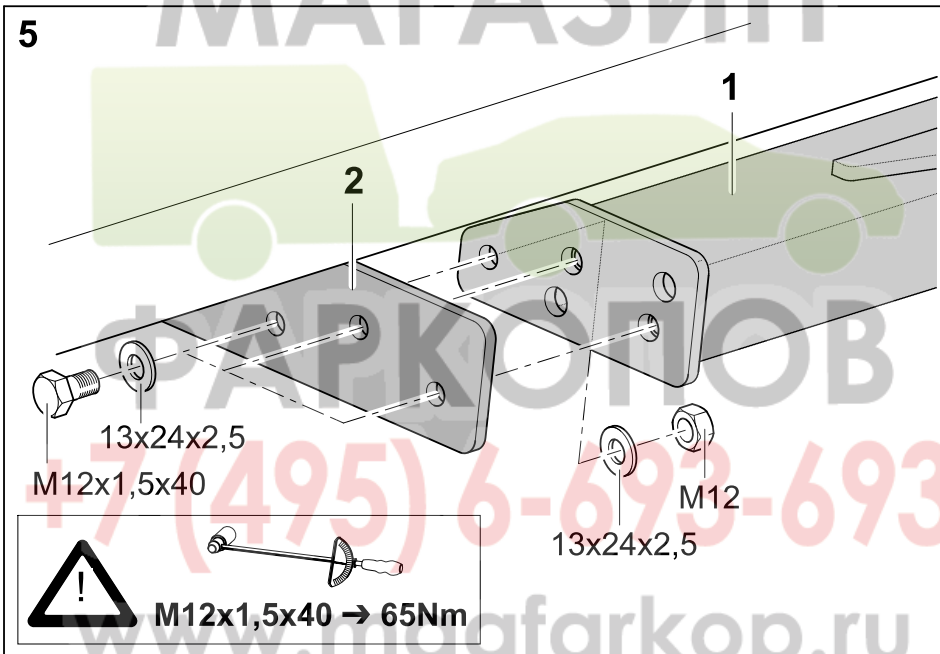
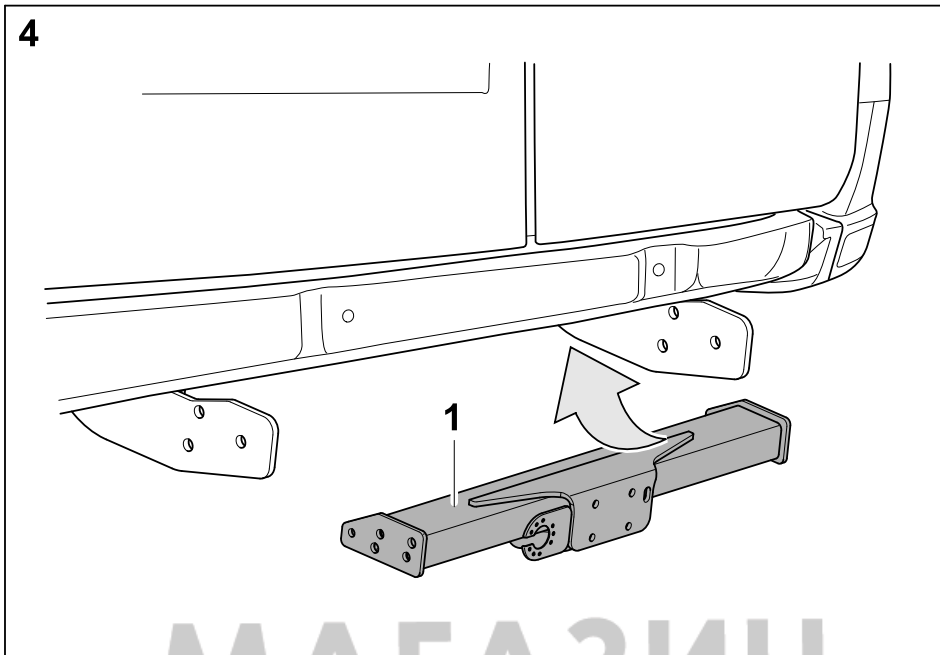

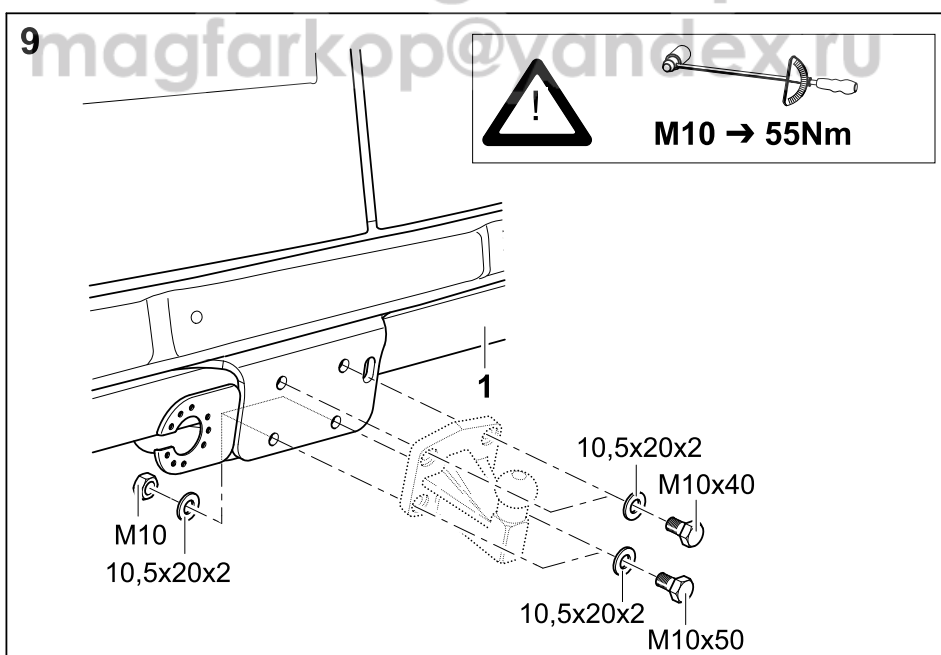
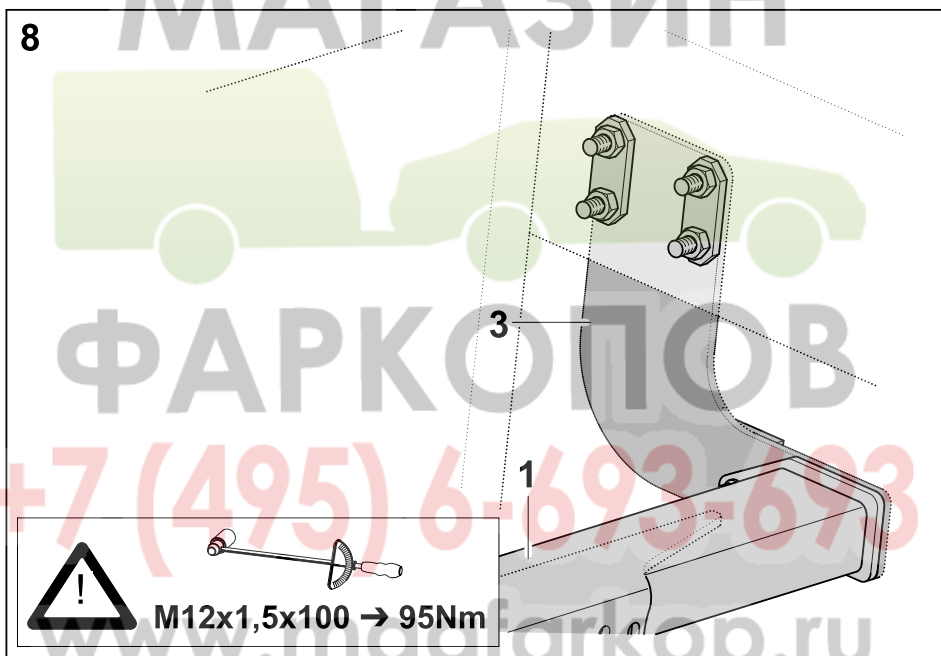
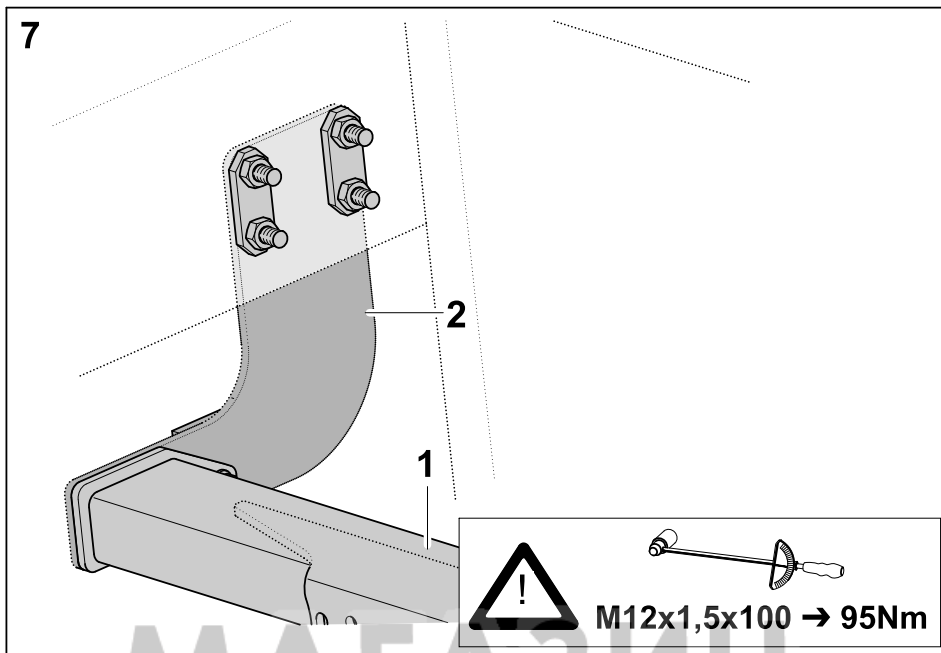

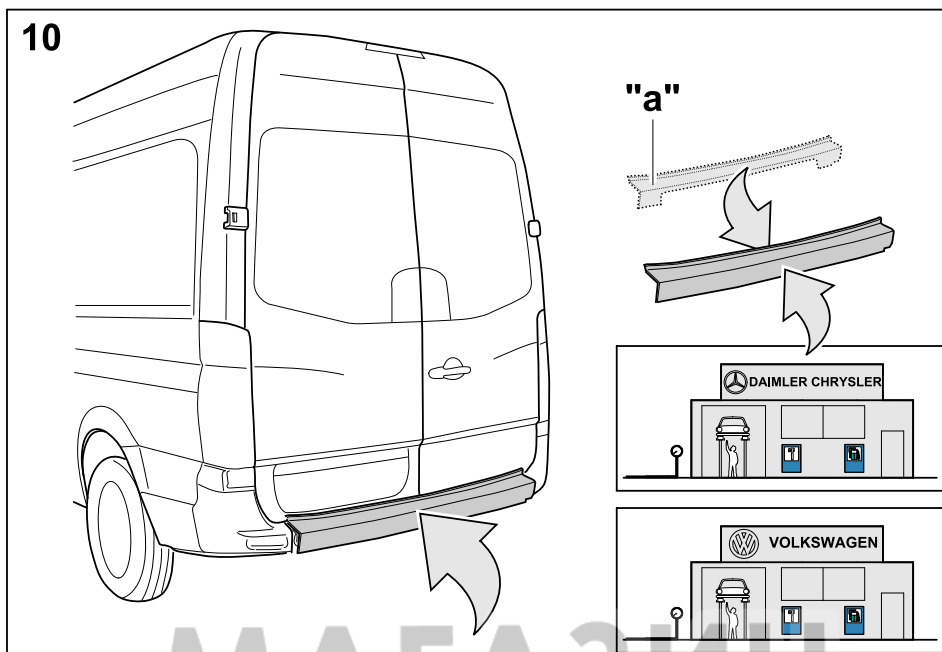

МАГАЗИН



ФАРКОПОВ

+7 (495) 6-693-693

www.magfarkop.ru

magfarkop@yandex.ru

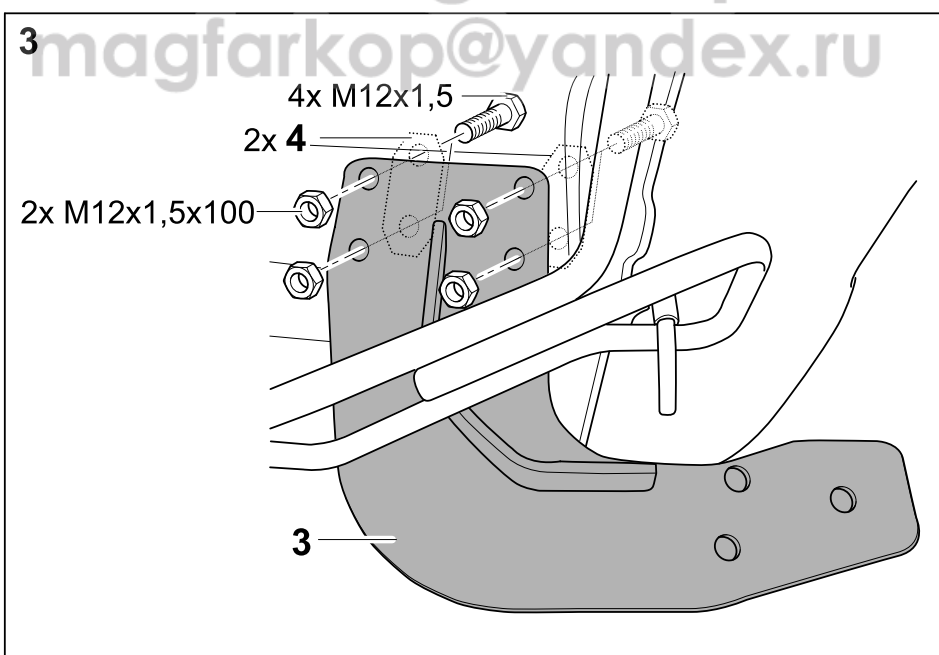
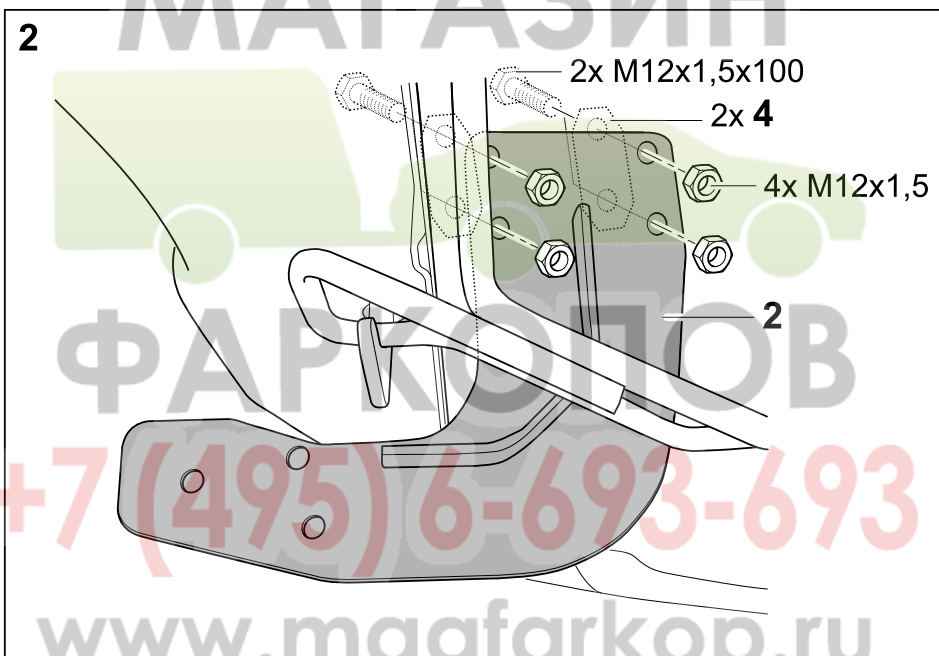
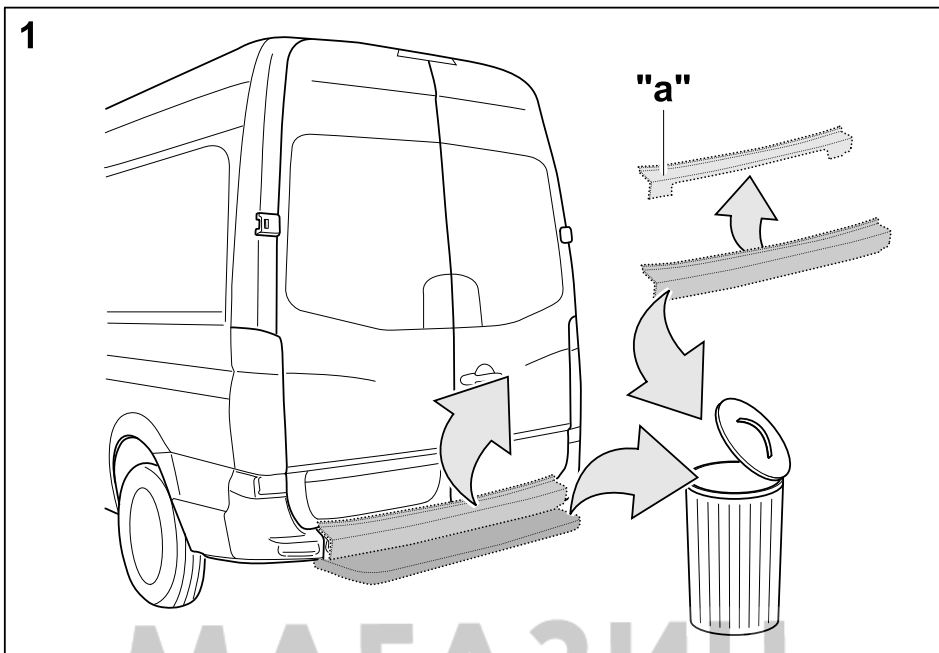

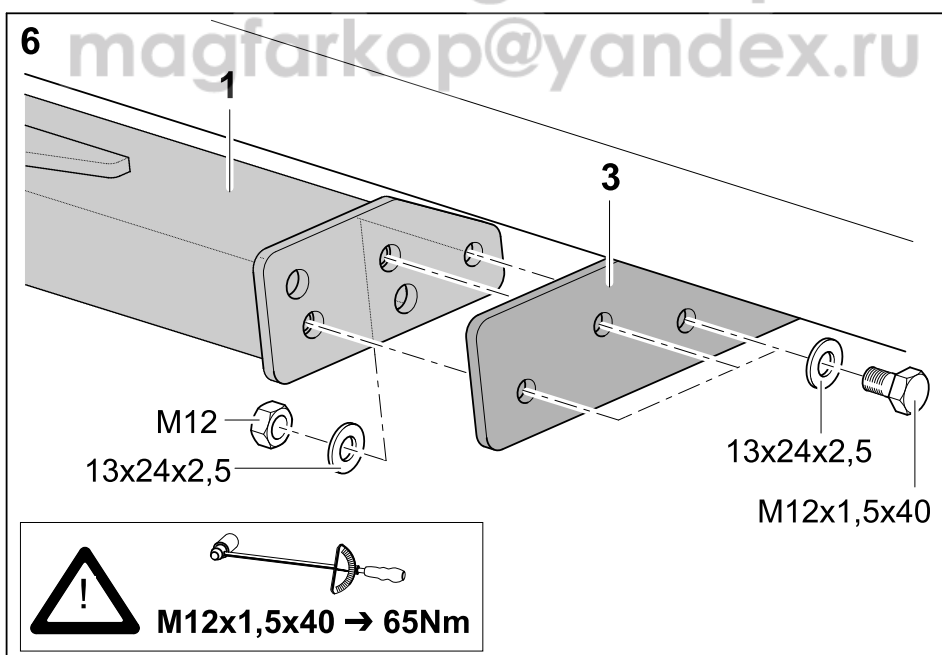
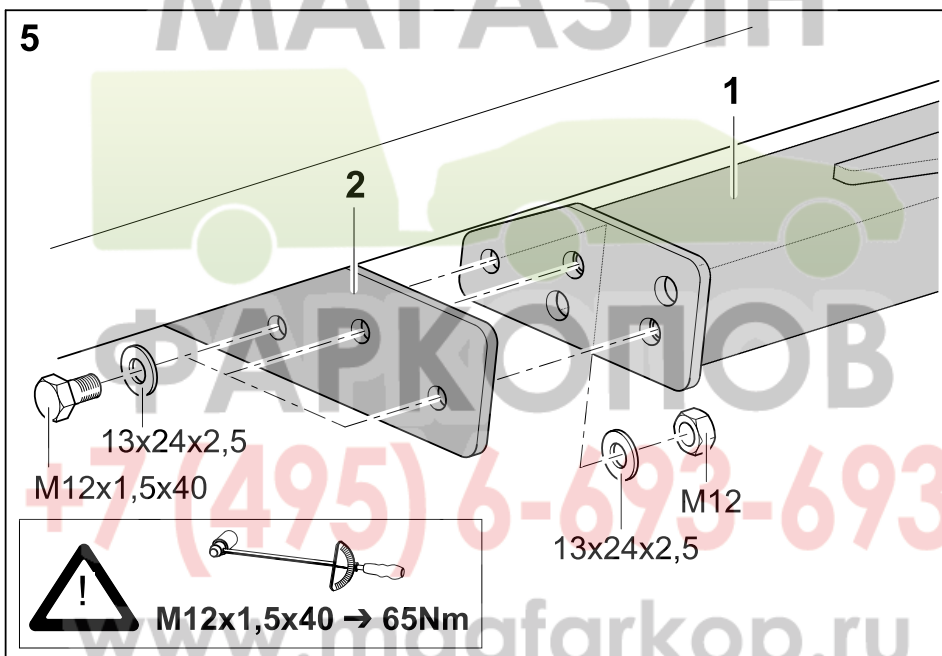
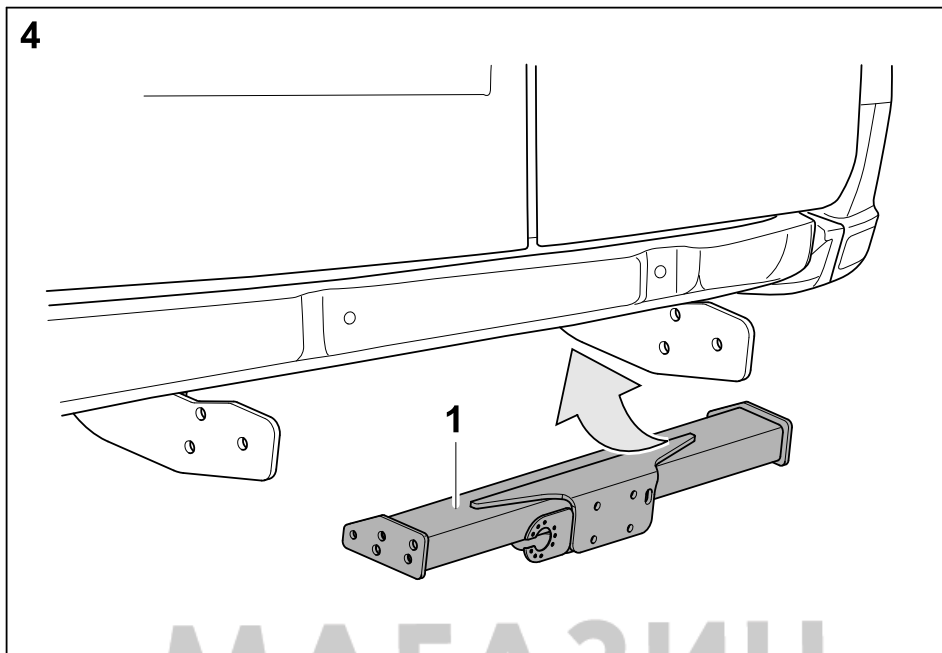

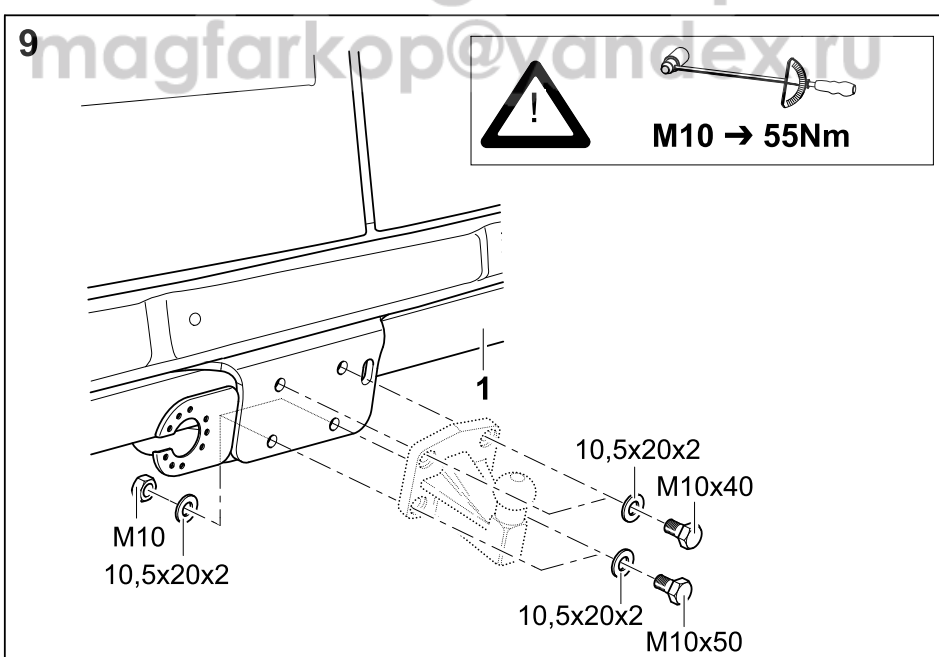
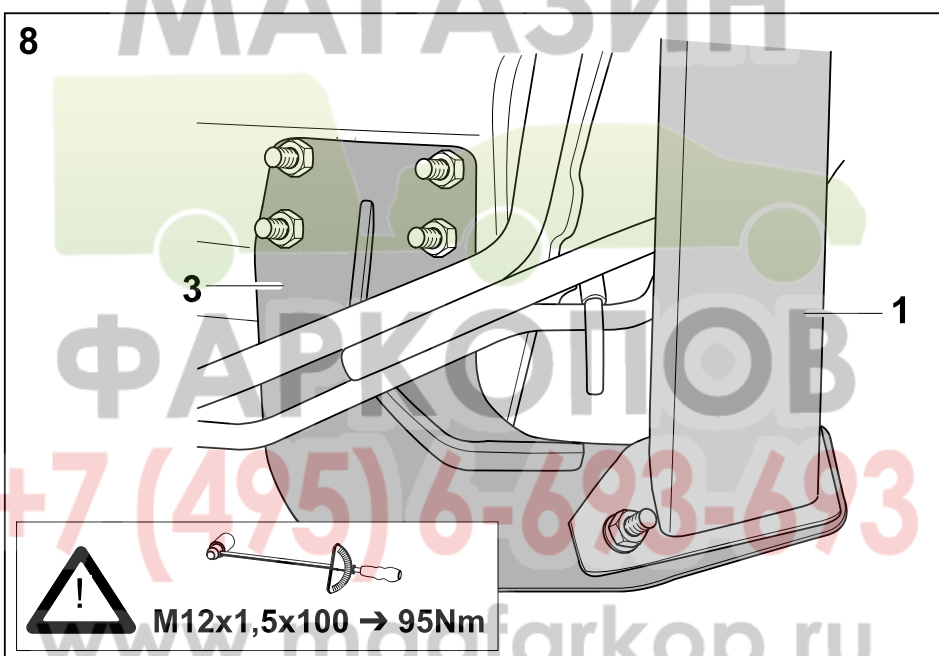
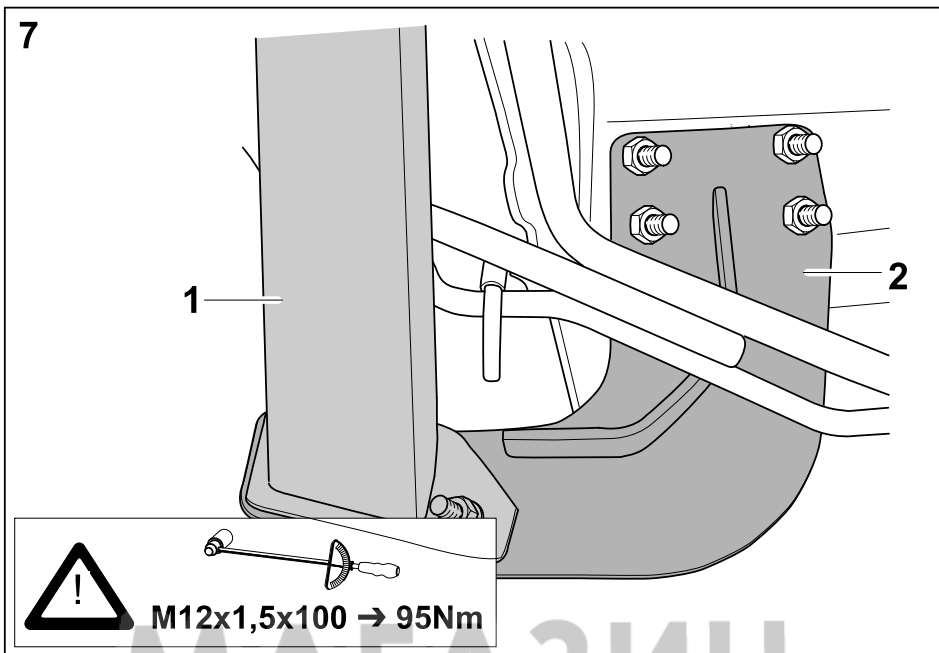

10

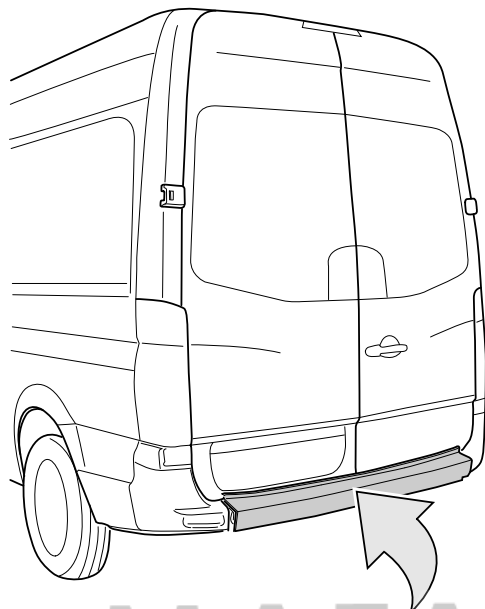

"a"

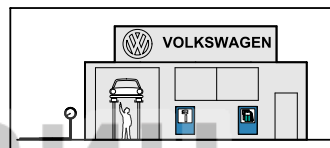
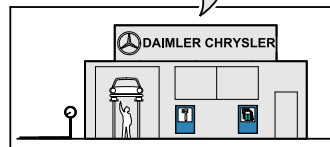
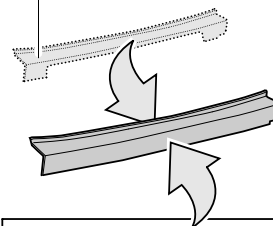

МАГАЗИН



ФАРКОПОВ

+7 (495) 6-693-693

www.magfarkop.ru

magfarkop@yandex.ru