

Fitting instructions

Jeep

Compass; 2006->

Patriot; 2007->

Type: 4524

МАГАЗИН



ФАРКОПОВ

+7 (495) 6-693-693

www.magfarkop.ru

magfarkop@yandex.ru

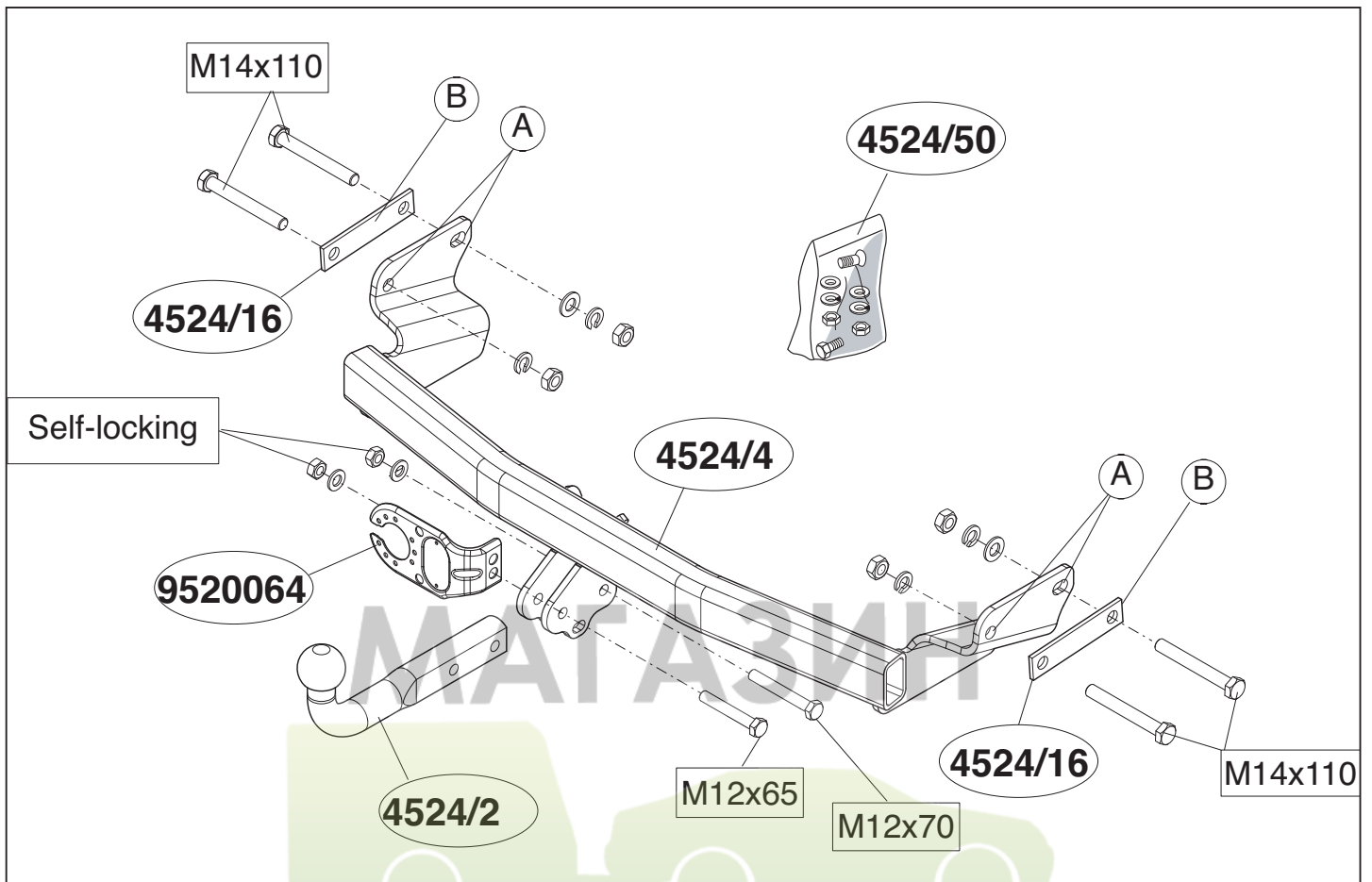

© 452470/24-09-2007/1

МАГАЗИН

ФАРКОПОВ

+7 (495) 6-693-693

www.magfarkop.ru

magfarkop@yandex.ru

© 452470/24-09-2007/14

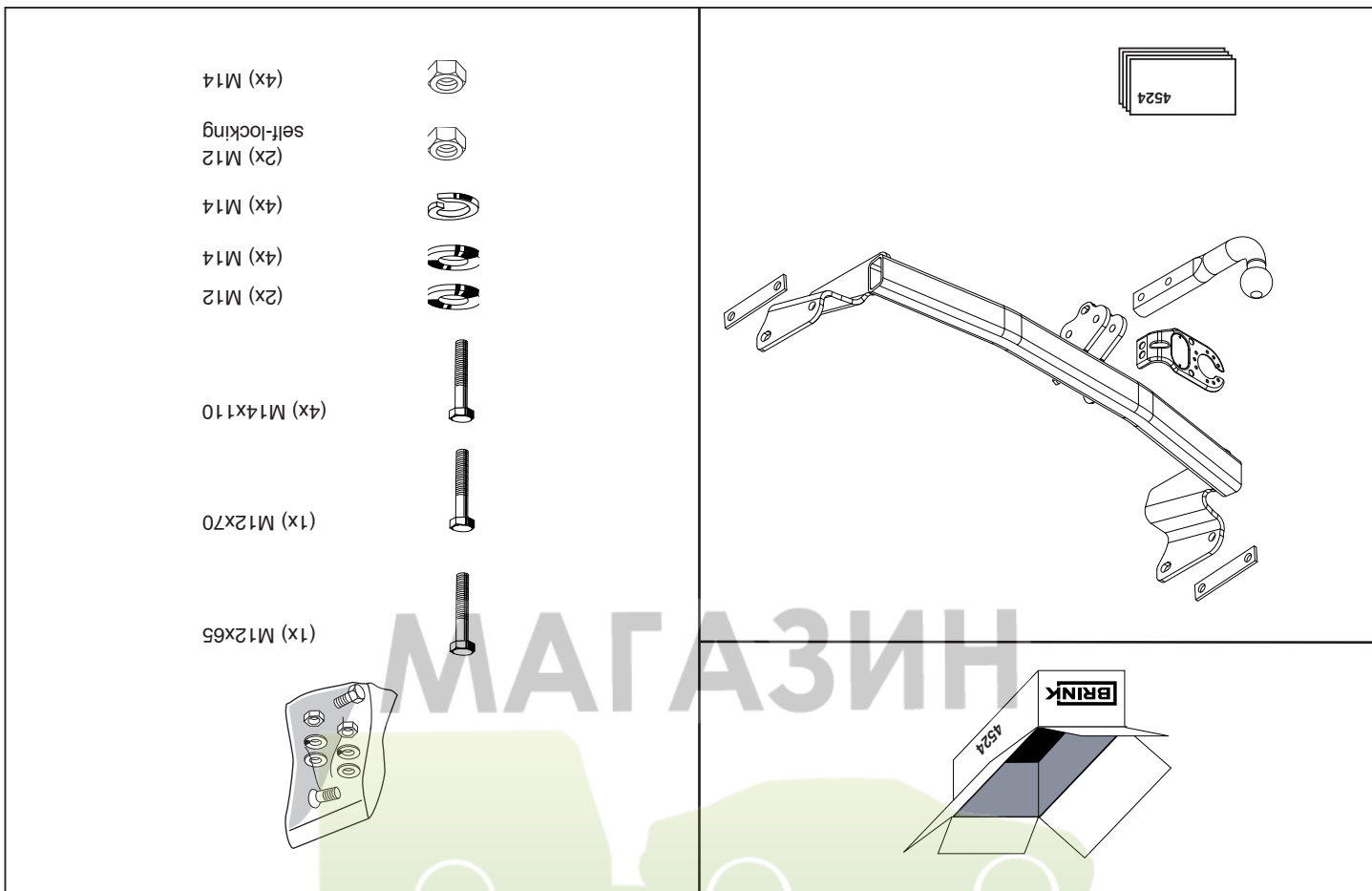

МАГАЗИН

+7 (495) 6-693-693

www.magfarkop.ru
magfarkop@yandex.ru

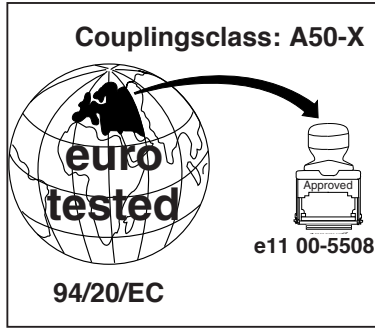
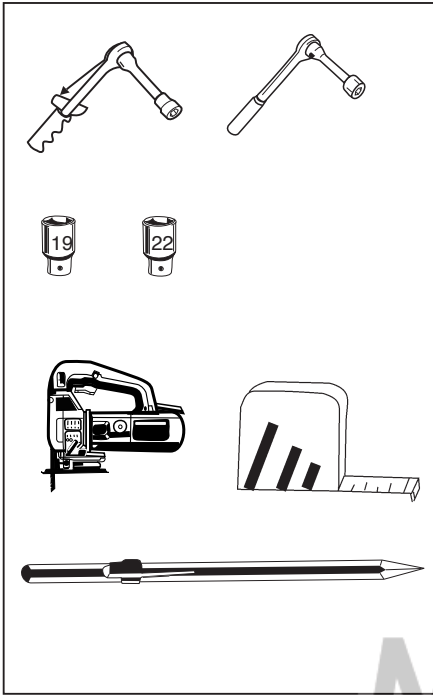

D-Value :8,7 kN

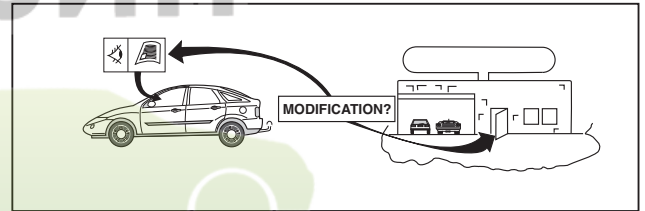
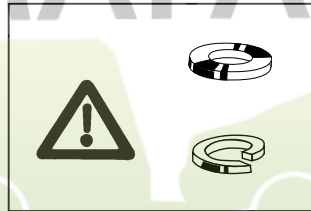
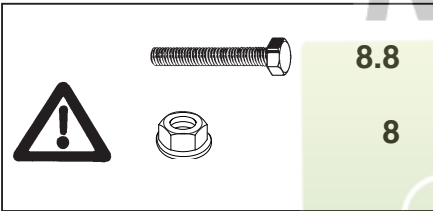
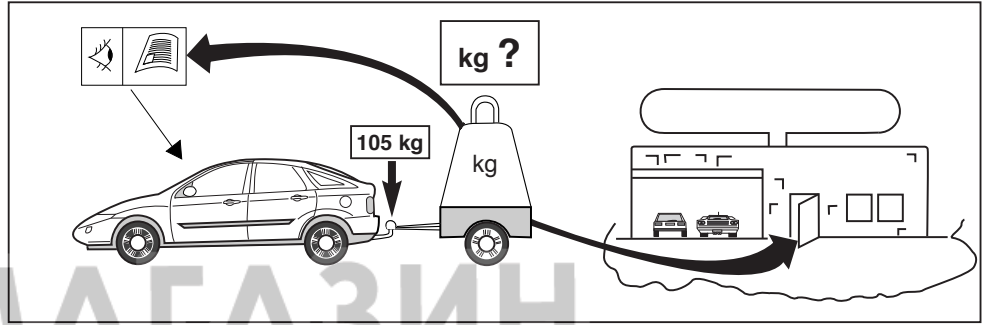

© 452470/24-09-2007/3

МАГАЗИН
ФАРКОПОВ

Dispositivo di traino tipo: 4524
Per autoveicoli:
Tipo funzionale:

Jeep Compass;2006-> / Jeep Patriot; 2007->

Classe e tipo di attacco: A50-X
Omologazione:
Valore D:

8.8
e11 00-5508
8,7 kN

Carico Verticale max. S:

105 kg

Larghezza rimorchiabile per Caravan e T.A.T.S.: 2,45m vedere CARTA di CIRCOLAZIONE VEICOLO (motrice) + 70 cm = ..arrotondare ai 5 cm superiore (vedi D.M.28/05/85)

Massa rimorchiabile: vedi carta di circolazione dell' autoveicolo

Per verificare l'idoneità del dispositivo di traino omologato a norma CEE 94/20, all'installazione sulla vettura su cui si intende procedere al montaggio, compilare la seguente formula (se necessario declassare la massa rimorchiabile):

$$D = \frac{T \times C}{T + C} \times 0,00981 \leq 8,7 \text{ kN}$$

dove: T= Massa Complessiva Max. della motrice (in kg)
C= Massa Rimorchiabile Max. della motrice (in kg)

DA COMPILARE PER IL COLLAUDO

DICHIARAZIONE DI CORRETTO MONTAGGIO: la sottoscritta Ditta dichiara di aver montato in maniera corretta ed in conformi/ alle prescrizioni sia del costruttore del veicolo che del costruttore del dispositivo stesso il seguente dispositivo di attacco meccanico:

tipo:.....
Il dispositivo di attacco sopra indicato è stato installato su autoveicolo
modello:.....
targa:.....
Data:.....

TIMBRO e FIRMA

Si dichiara inoltre di aver informato l'utente del veicolo sull'USO e MANUTENZIONE del dispositivo stesso.

* Die für das Fahrzeug zugelassene Anhängelast ist den Fahrzeug Unterlagen zu entnehmen. Bei Änderungen des Fahrzeuggewichtes muß die höchstzulässige Anhängelast gegebenenfalls aus dem D-Wert nachgerechnet werden.
* Elektrische Anlage gemäß StVZO anbringen.
* Auskunft hierzu kann Ihr Fachhändler oder der TÜV geben.

HINWEISE:

All measurements are in mm!

* Should this installation process entail the cutting of the bumper – conformation MUST be obtained by the installation engineer or the customer's acceptance prior to completion. Thule Towing Systems do not accept responsibility for any matters arising as a result of this miscommunication.

NOTE:

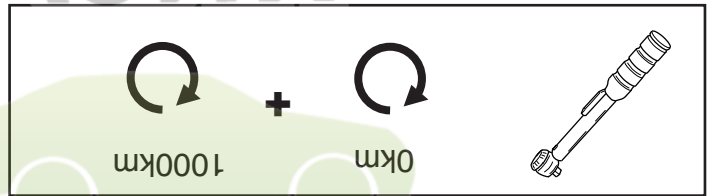

МАГАЗИН
ФАРКОПОВ
+7 (495) 9-693-693

www.magfarkop.ru
magfarkop@yandex.ru

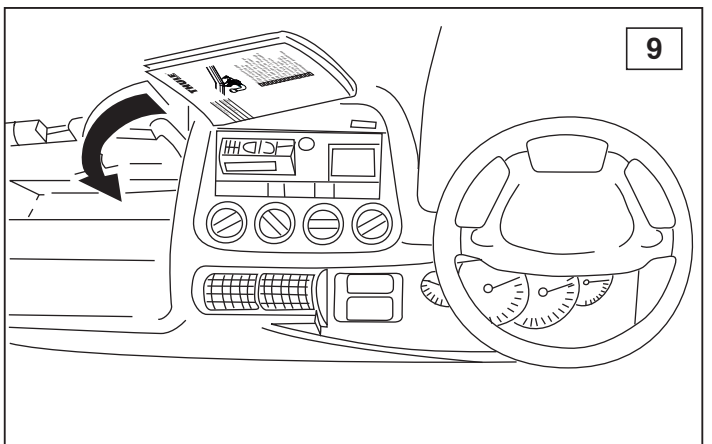

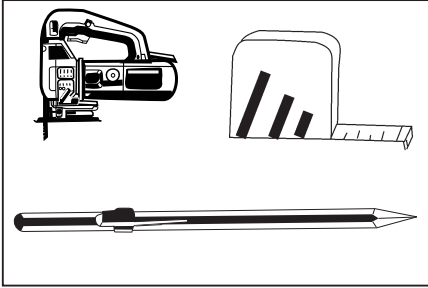

Use Template 4524 COMPASS

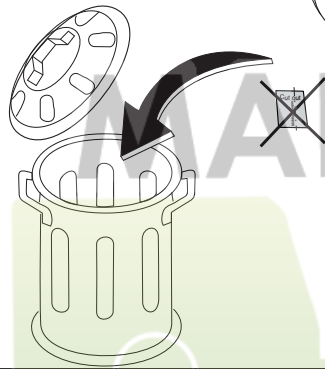
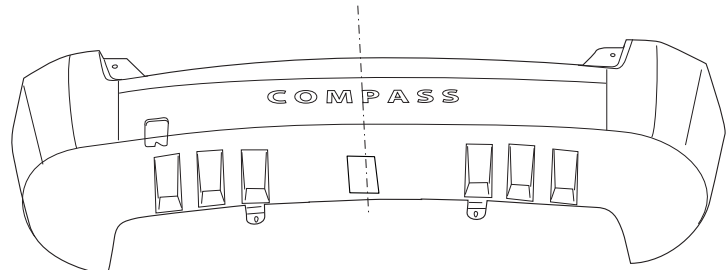
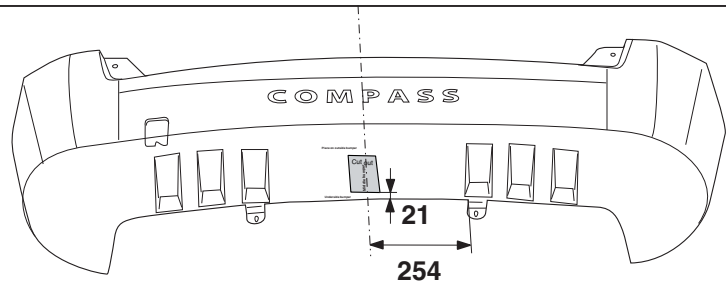

1

© 452470/24-09-2007/5



+7 (495) 6-693-693

www.magfarkop.ru

magfarkop@yandex.ru

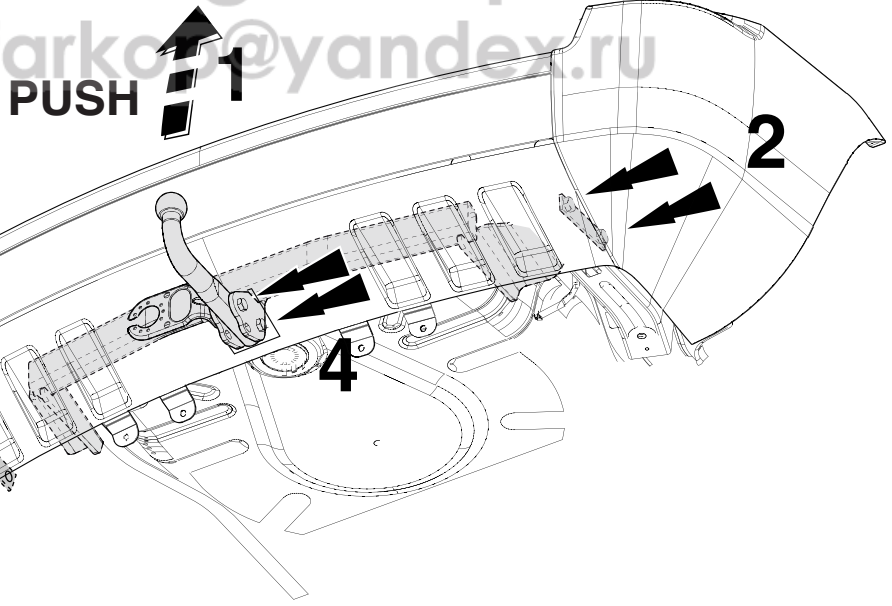
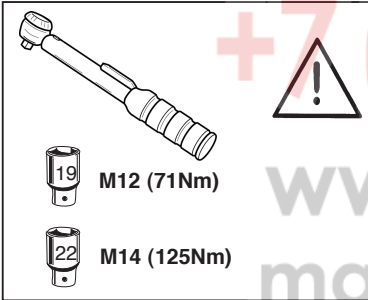

5

© 452470/24-09-2007/10

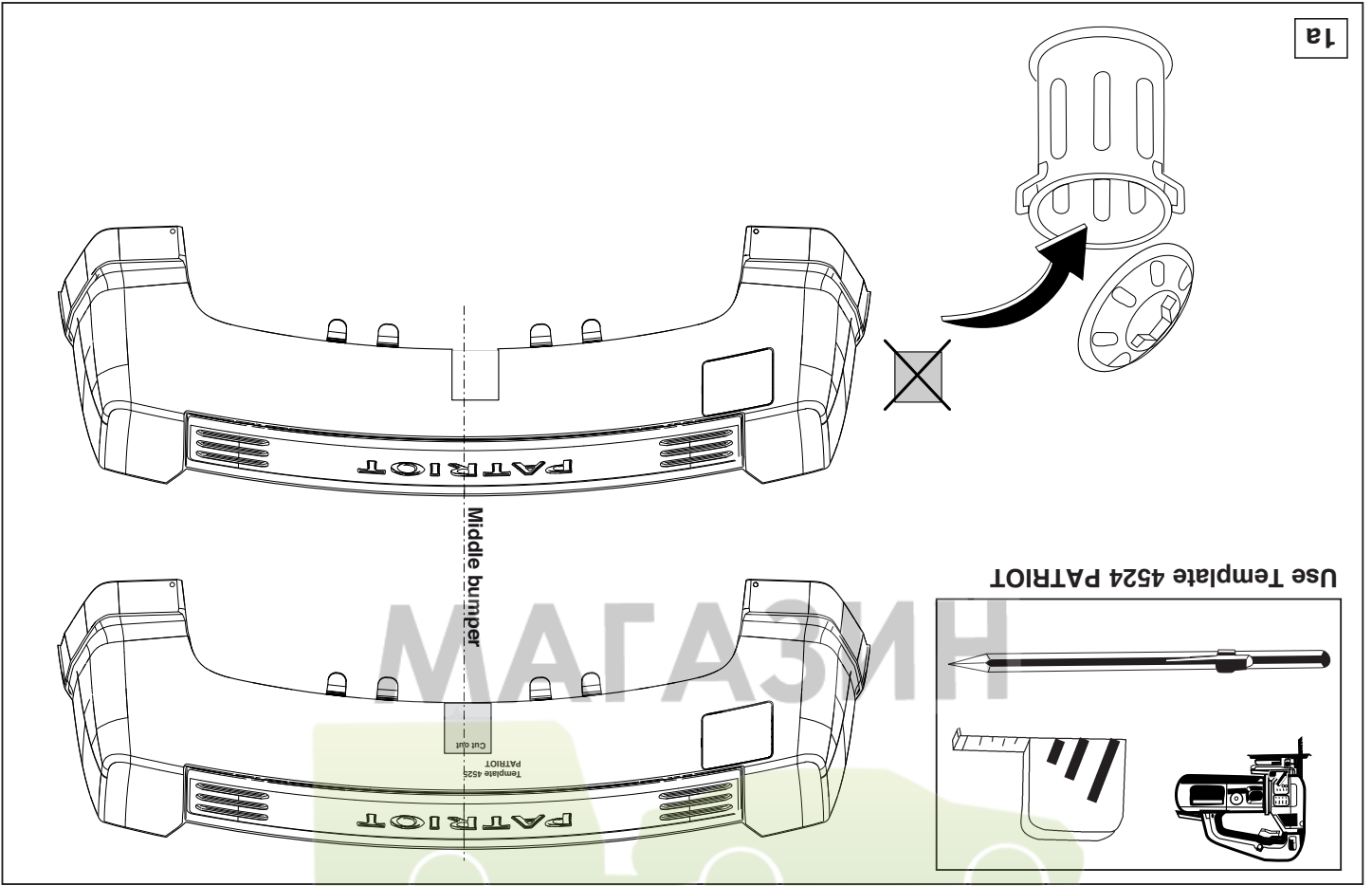

1a

Use Template 4524 PATRIOT

Middle bumper

Cut out

Template 4524

PATRIOT

МАГАЗИН
ФАРКОПОВ

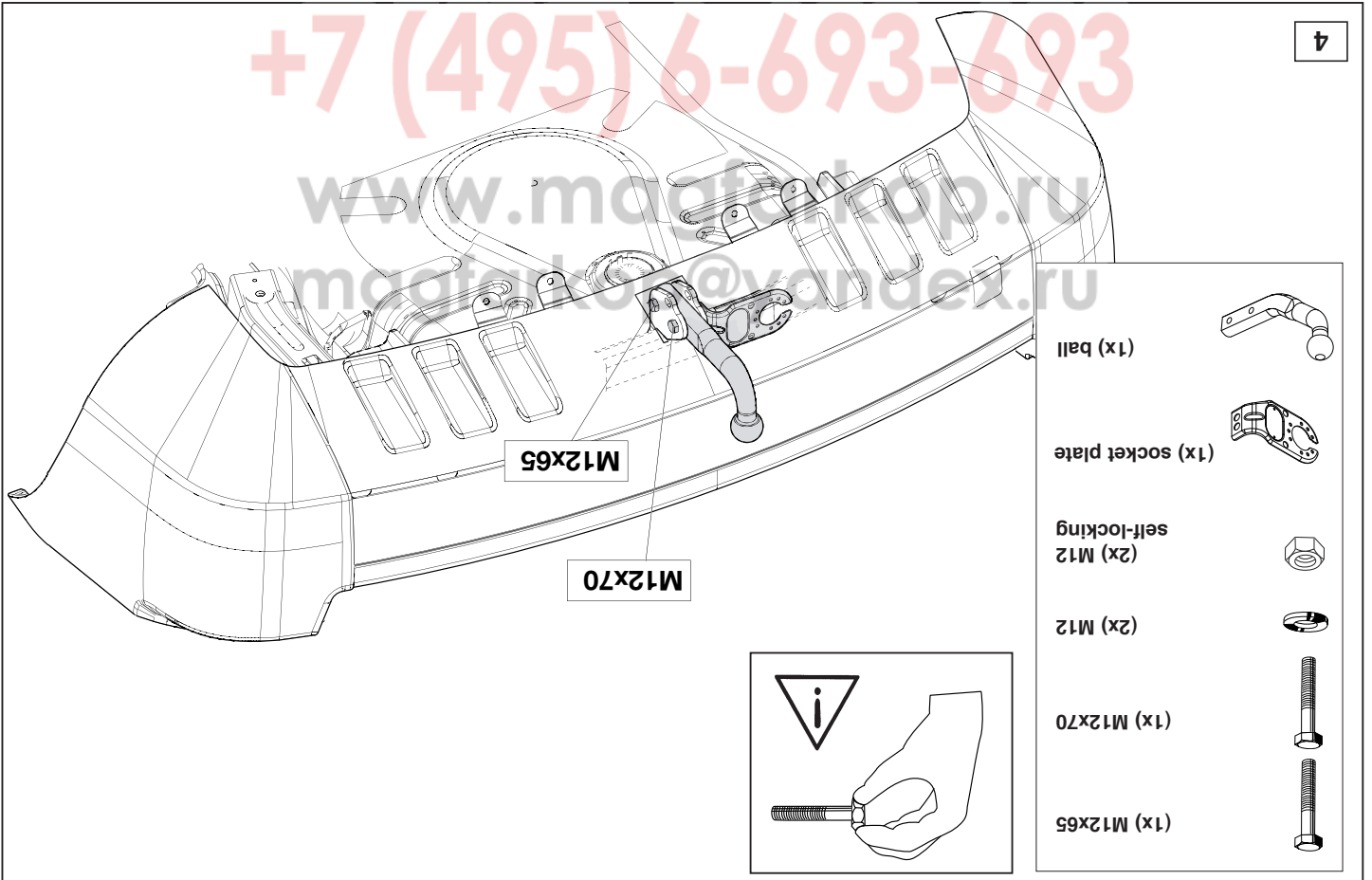

4

(1x) ball

(1x) socket plate

(2x) M12 self-locking

(2x) M12

(1x) M12x70

(1x) M12x65

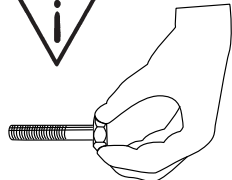

+7 (495) 6-693-693

www.magafarop.ru

magafarop@yandex.ru

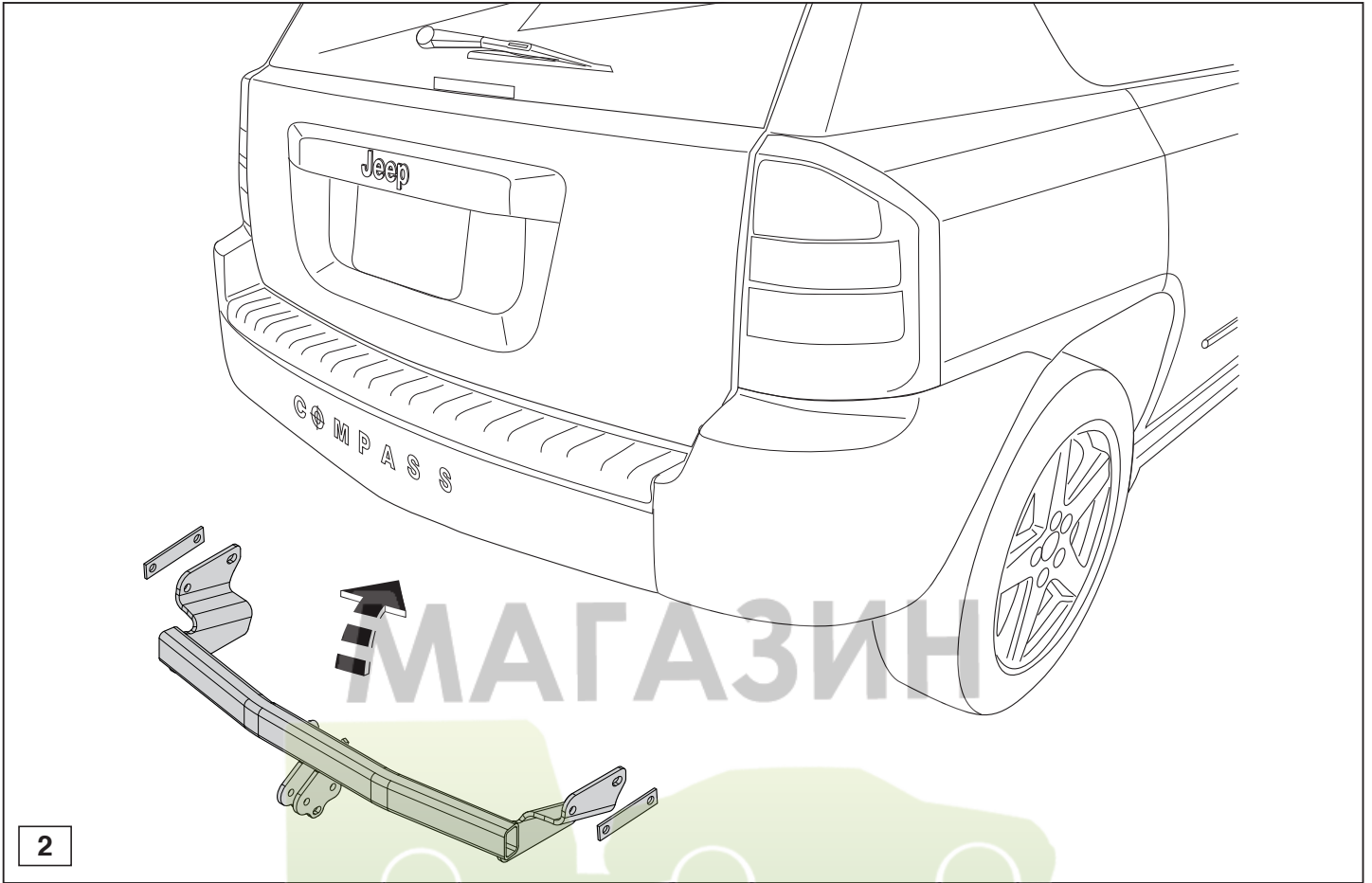

2

© 452470/24-09-2007/7

МАГАЗИН
ФАРКОПОВ

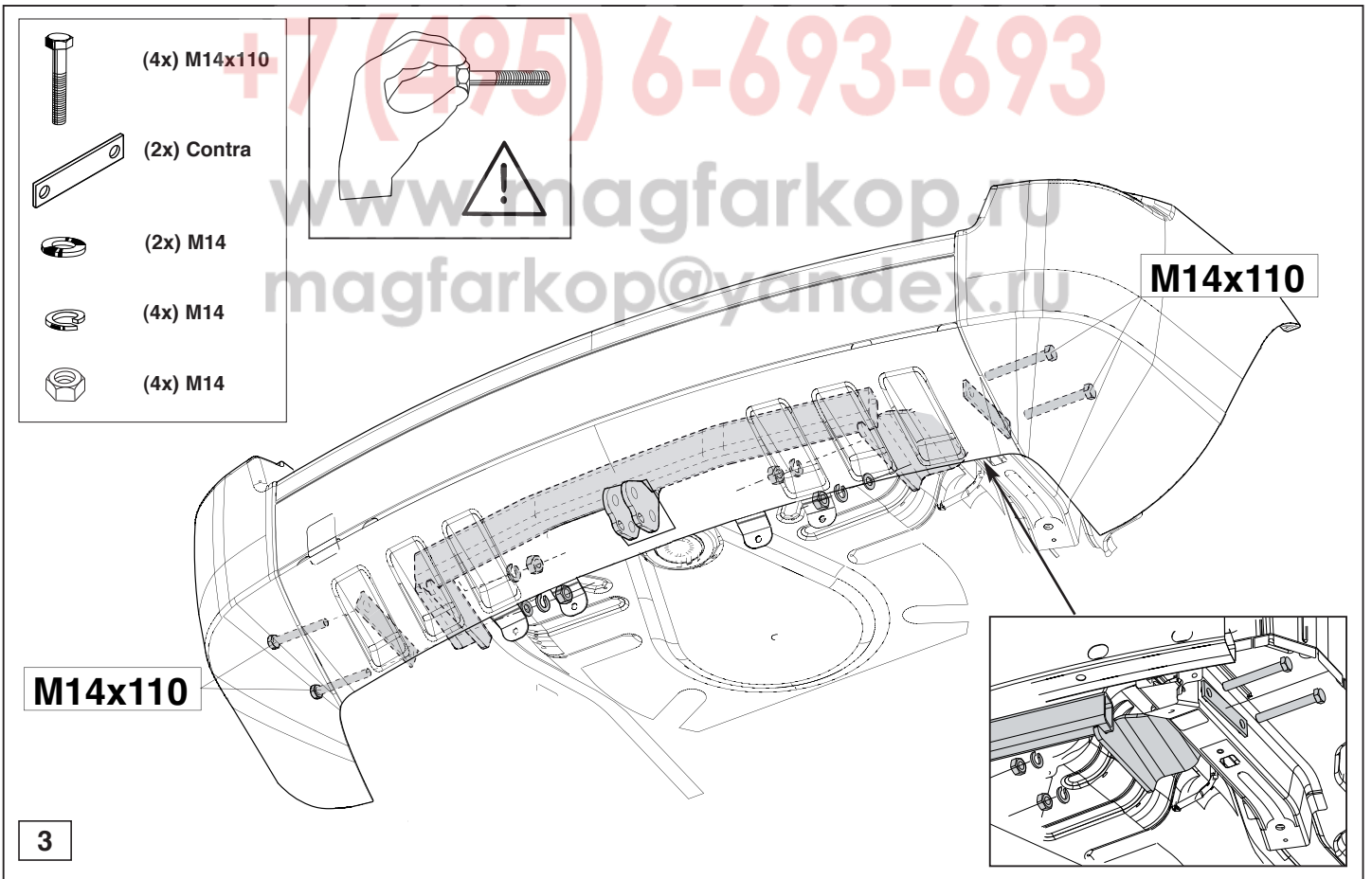

3

© 452470/24-09-2007/8