

Fitting instructions

Make: Mazda/Ford

BT-50 (4x4); 2006->

B-2500 (4x4); 1999 - 2006

Ranger; 1999 ->

Type: 4826

МАГАЗИН



ФАРКОПОВ

+7 (495) 6-693-693

www.magfarkop.ru

magfarkop@yandex.ru

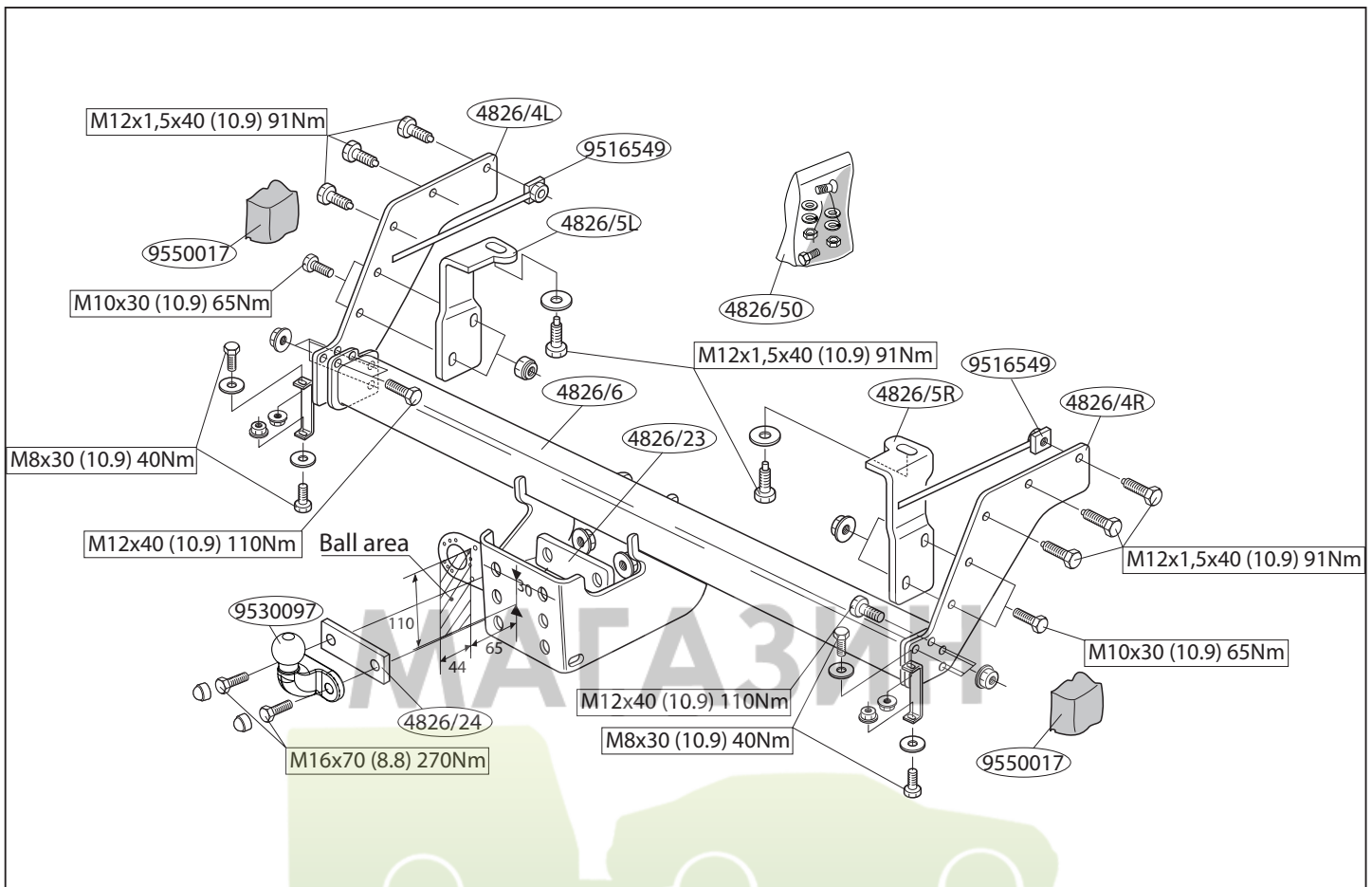

© 482670MN/08-08-2007/1

Dispositivo di traino tipo: 4826
 Per autoveicoli: Mazda BT-50 (4x4); 2006->
 B-2500 (4x4); 1999 - 2006
 Ford Ranger; 1999->

Tipo funzionale:

Classe e tipo di attacco: F

Omologazione: e11 00-6367 / e4 00-5950

Valore D: 15,0 kN

Carico Verticale max. S: 125 kg

Larghezza rimorchiabile per Caravan e T.A.T.S.: 2,45m vedere CARTA di CIRCOLAZIONE VEICOLO (motrice) + 70 cm = ..arrotondare ai 5 cm superiore (vedi D.M.28/05/85)

Massa rimorchiabile: vedi carta di circolazione dell' autoveicolo

Per verificare l'idoneità del dispositivo di traino omologato a norma CEE 94/20, all'installazione sulla vettura su cui si intende procedere al montaggio, compilare la seguente formula (se necessario declassare la massa rimorchiabile):

$$D = \frac{T \times C}{T + C} \times 0,00981 \leq 15,0 \text{ kN}$$

dove: T= Massa Complessiva Max. della motrice (in kg)
 C= Massa Rimorchiabile Max. della motrice (in kg)

DA COMPILARE PER IL COLLAUDO

DICHIARAZIONE DI CORRETTO MONTAGGIO: la sottoscritta Ditta dichiara di aver montato in maniera corretta ed in conformità/ alle prescrizioni sia del costruttore del veicolo che del costruttore del dispositivo stesso il seguente dispositivo di attacco meccanico:

tipo:.....
 Il dispositivo di attacco sopra indicato è stato installato su autoveicolo
 modello:.....
 targa:.....
 Data:.....

TIMBRO e FIRMA

Si dichiara inoltre di aver informato l'utente del veicolo sull'USO e MANUTENZIONE del dispositivo stesso.

© 482670MN/08-08-2007/10

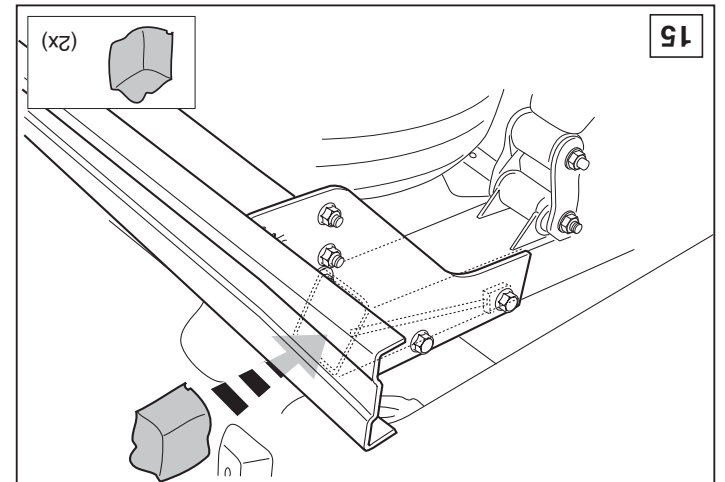
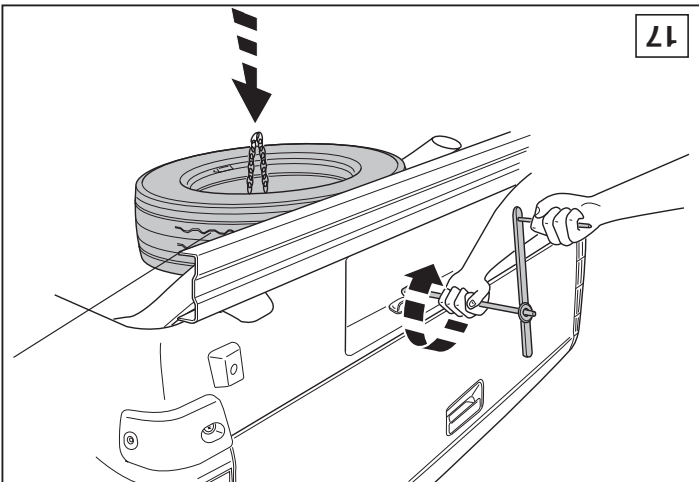
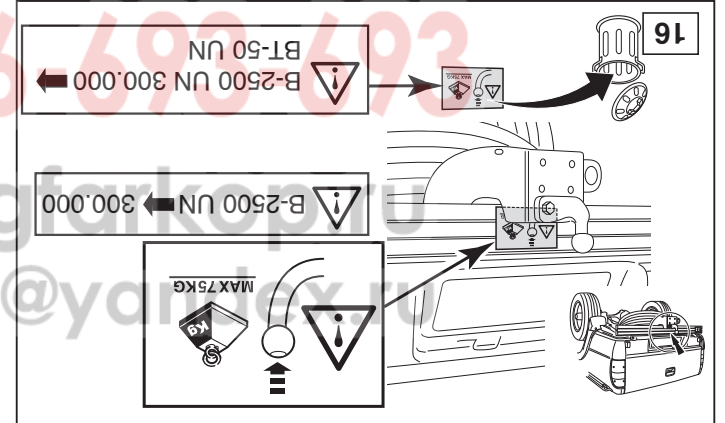
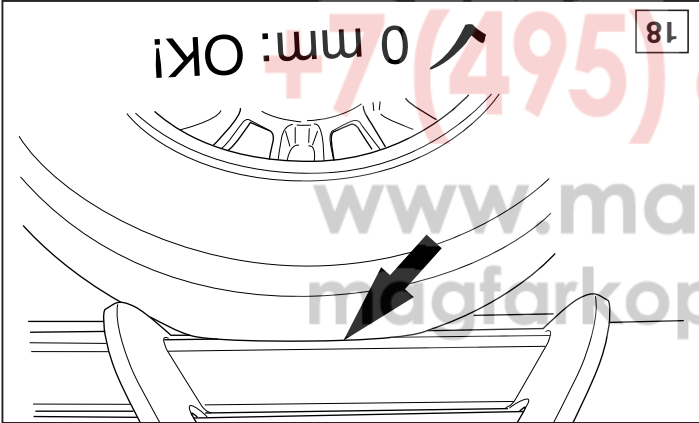
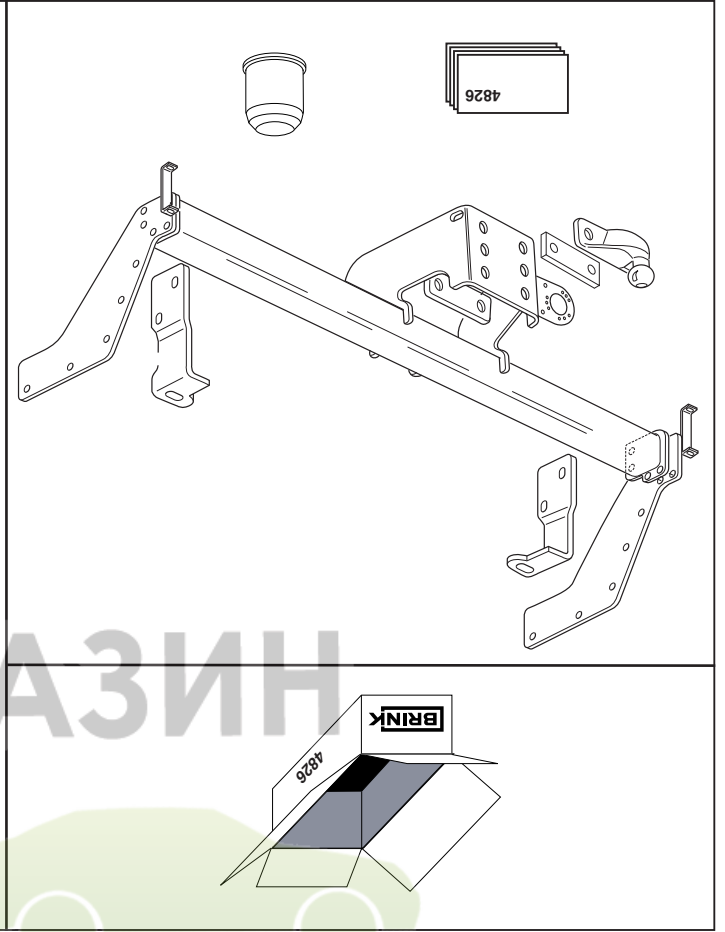
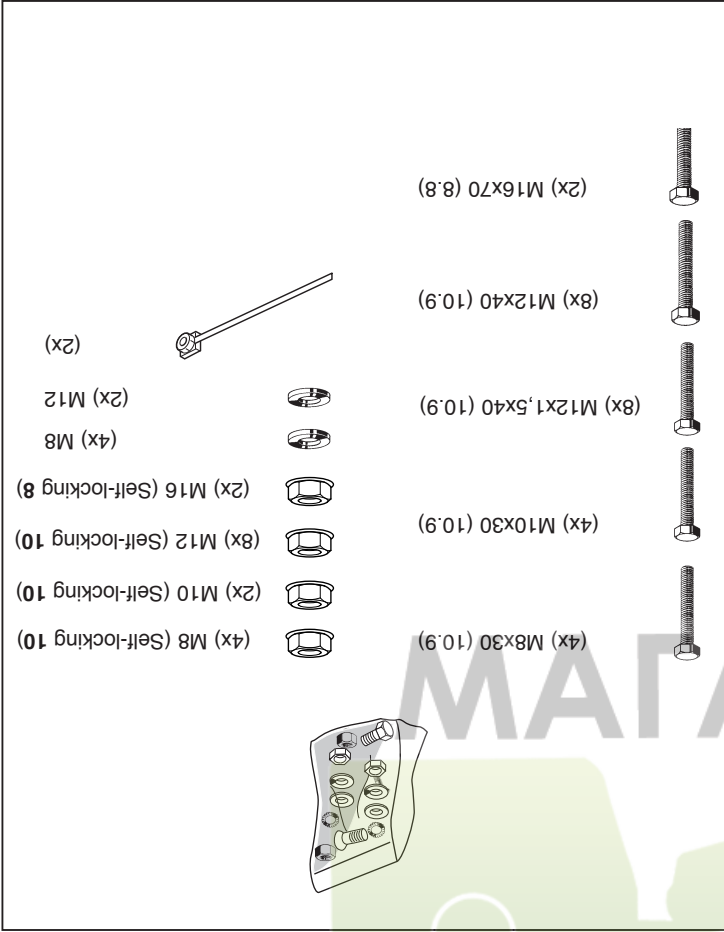

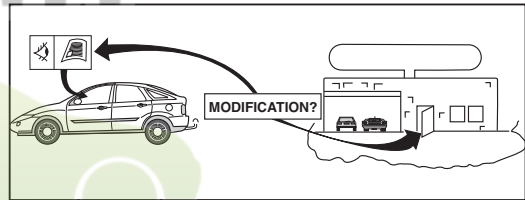
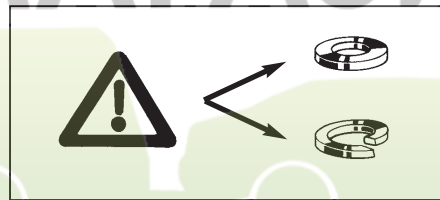
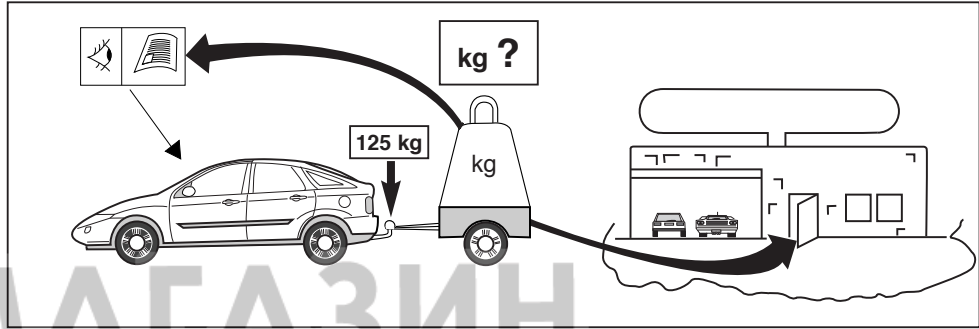
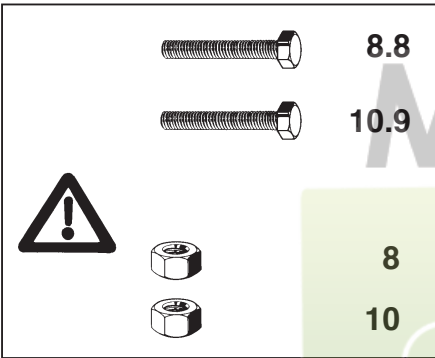
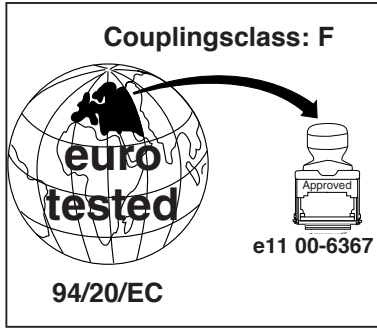
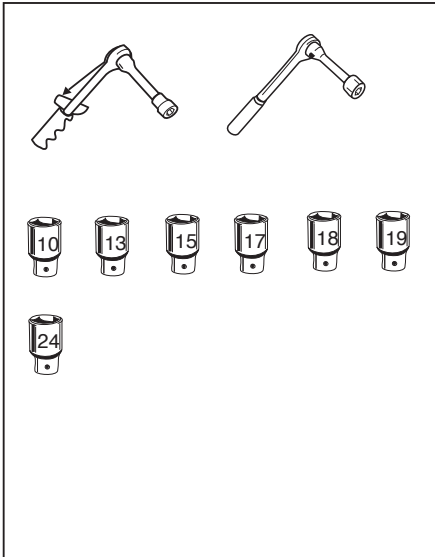

© 482670MN/08-08-2007/3

МАГАЗИН
ФАРКОПОВ

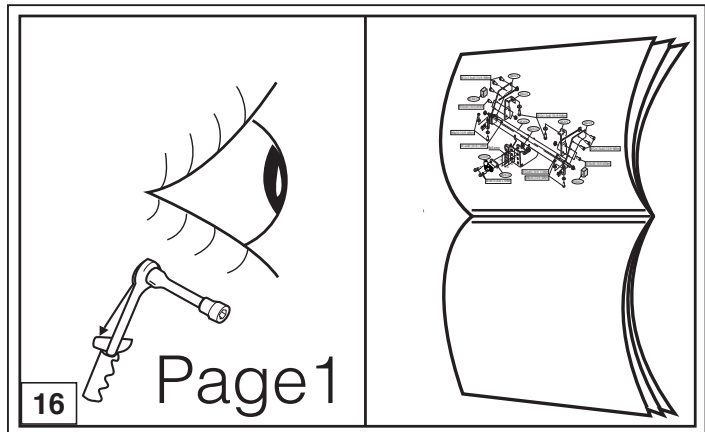
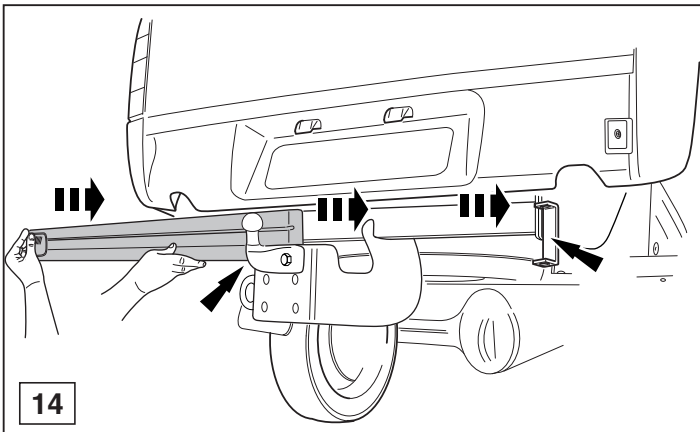
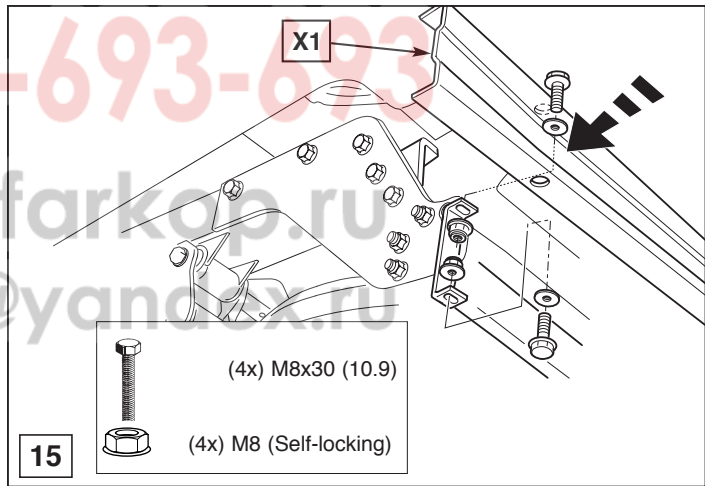
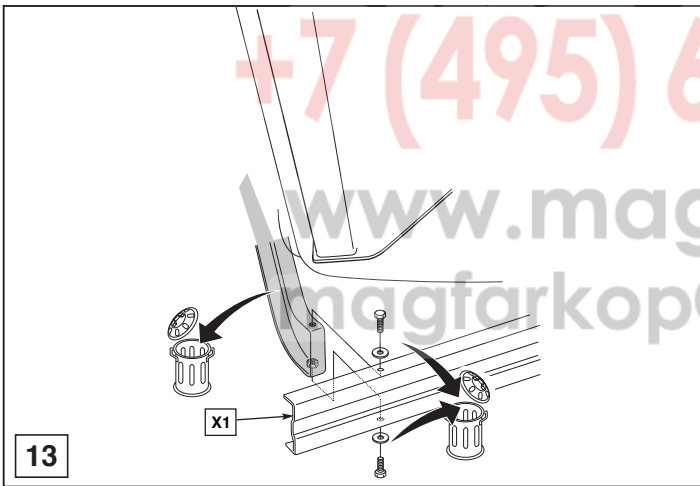

© 482670MN/08-08-2007/8

* Should this installation process entail the cutting of the bumper – conformation MUST be obtained by the installation engineer of the customer's acceptance prior to completion. Brink International do not accept responsibility for any matters arising as a result of this miscommunication.

NOTE:

* Für das Fahrzeug zugelassene Anhängelast ist den Fahrzeug Unterlagen zu entnehmen. Bei Änderungen des Fahrzeuggewichtes muß die höchstzulässige Anhängelast gegebenenfalls aus dem D-Wert nachgerechnet werden.
 * Elektrische Anlage gemäß SIVZO anbringen.
 * Auskunft hierüber kann Ihr Fachhändler oder der TÜV geben.

HINWEISE:



МАГАЗИН
 ФАРКОПОВ
 +7 (495) 6-693-693
 www.magfarkop.ru
 magfarkop@yandex.ru

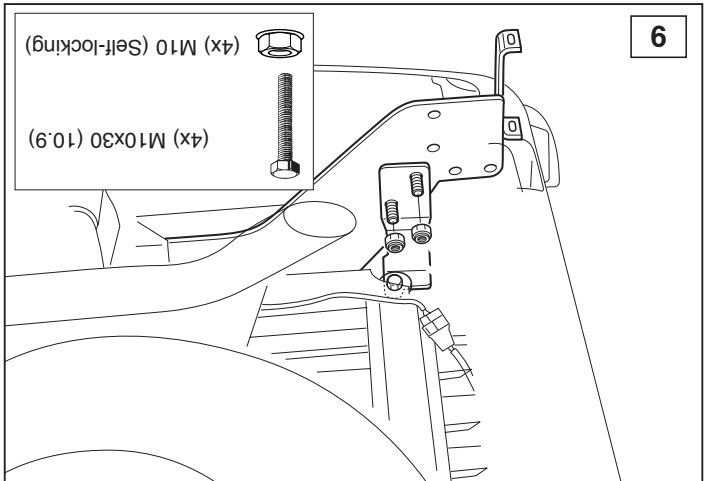
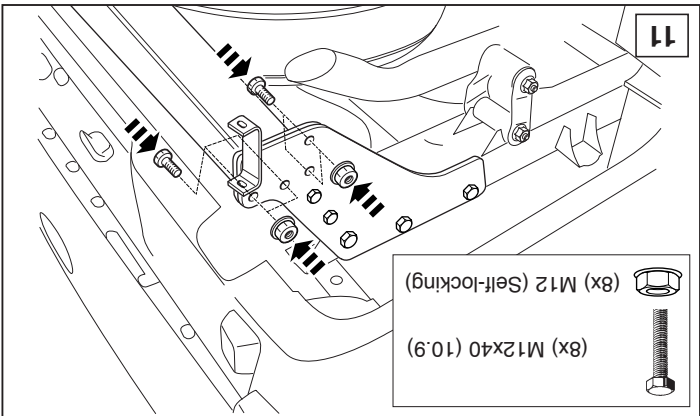
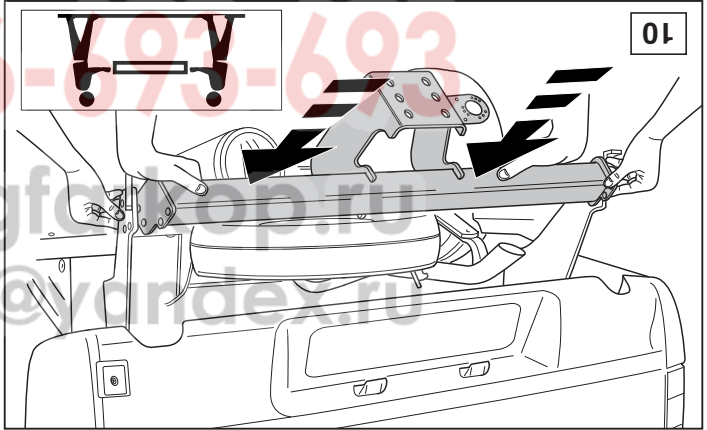
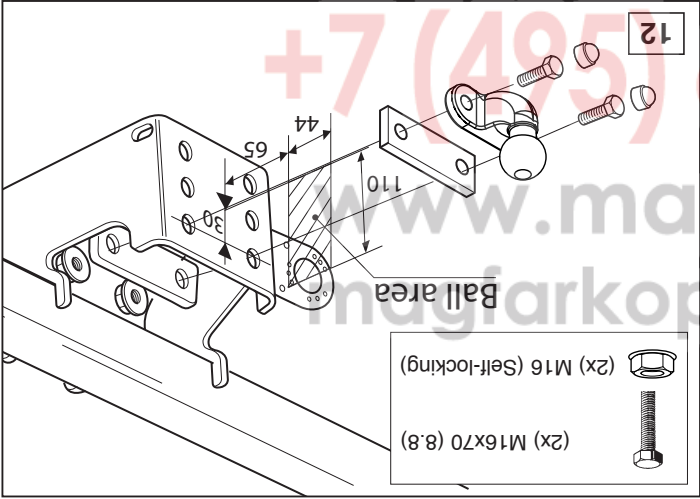

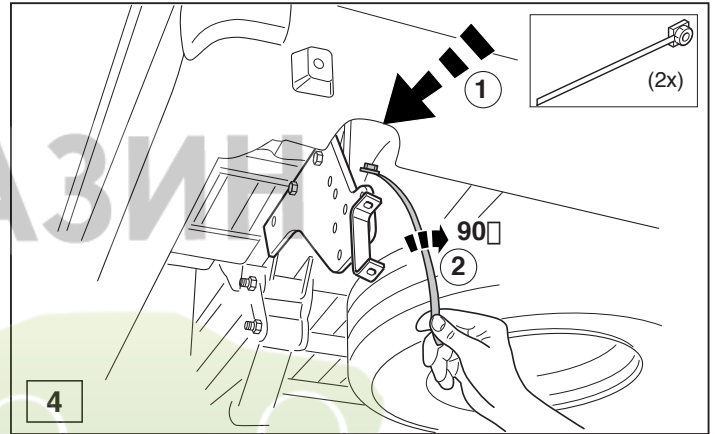
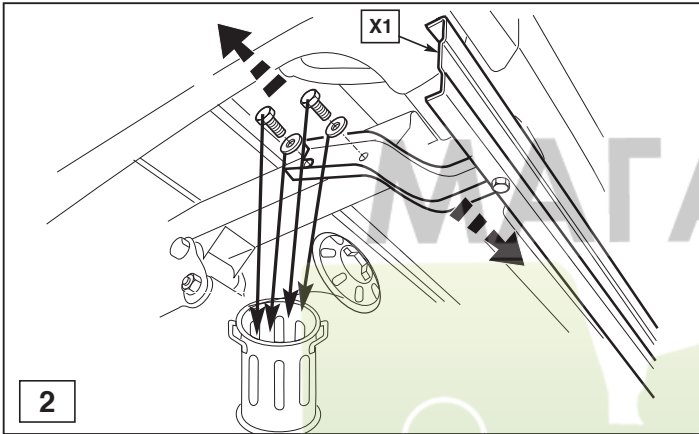
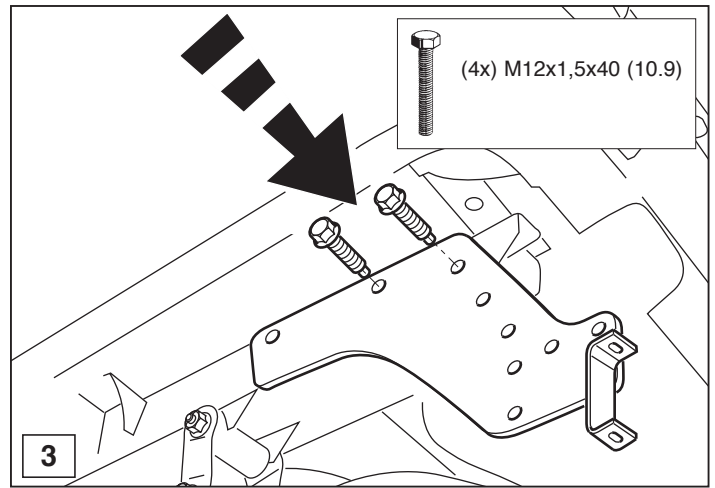
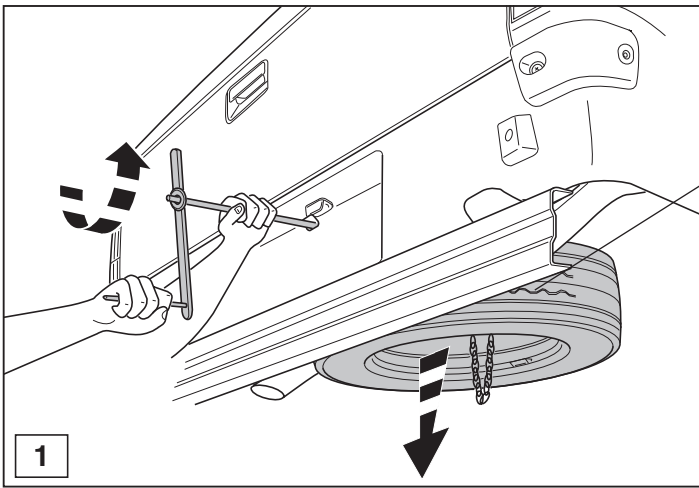

© 482670MN/08-08-2007/5

ФАРКОПОВ

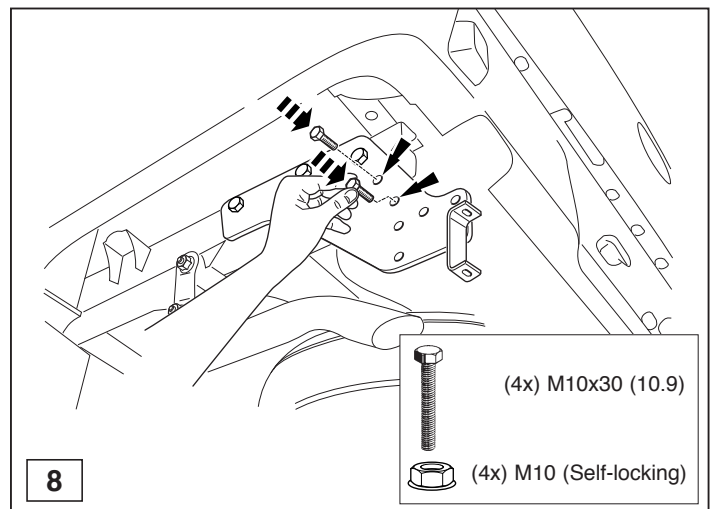
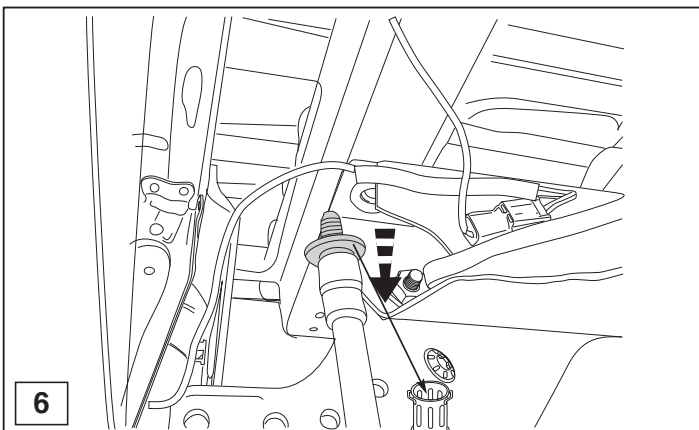
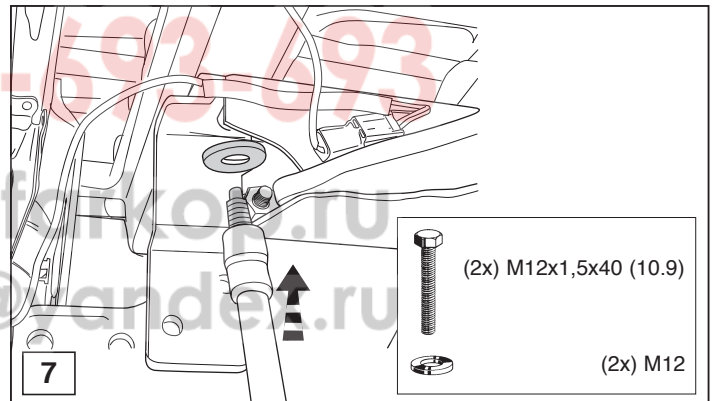
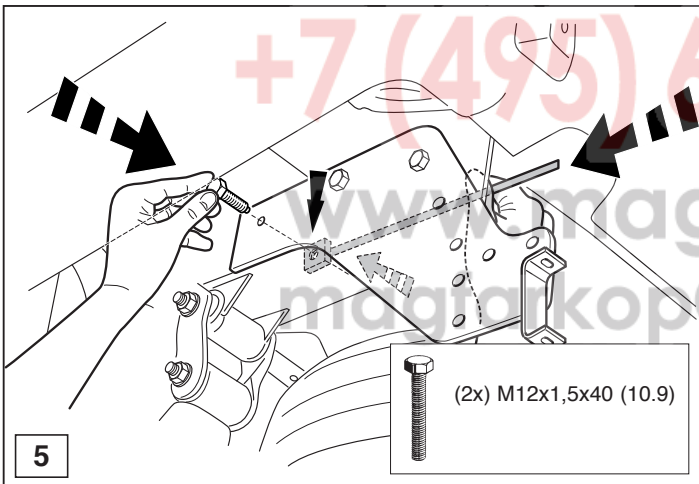

© 482670MN/08-08-2007/6