

Fitting instructions

Make: Infiniti

FX 30; 05/2010->

FX 37; 10/2008->

FX 50; 10/2008->

Type: 5509

МАГАЗИН



ФАРКОПОВ

+7 (495) 6-693-693

www.magfarkop.ru

magfarkop@yandex.ru

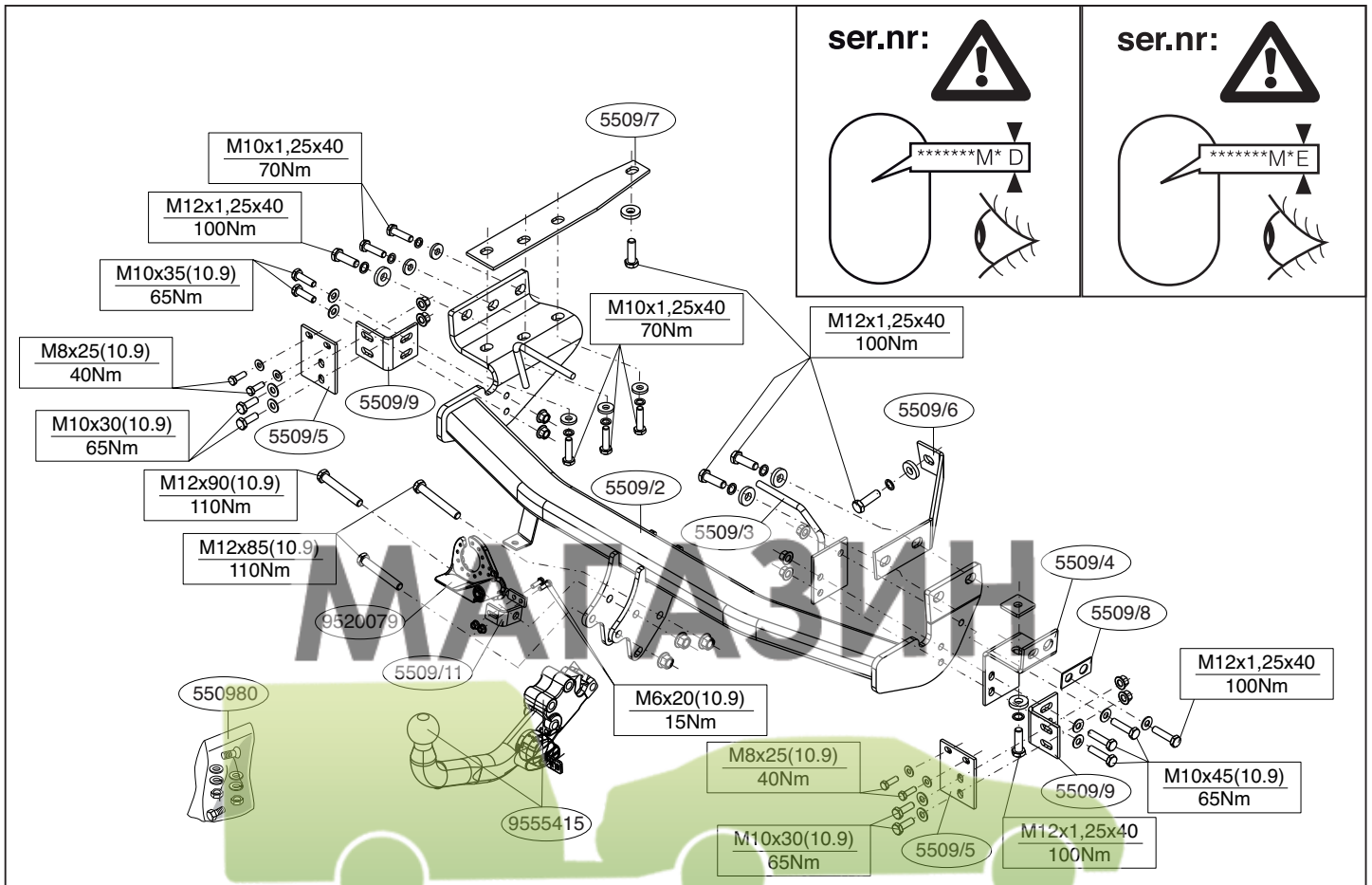

© 550970/02-02-2012/1

ФАРКОПОВ
+7 (495) 6-693-693

www.magfarkop.ru
magfarkop@yandex.ru

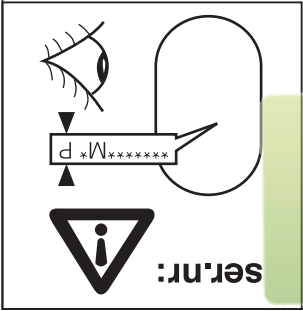
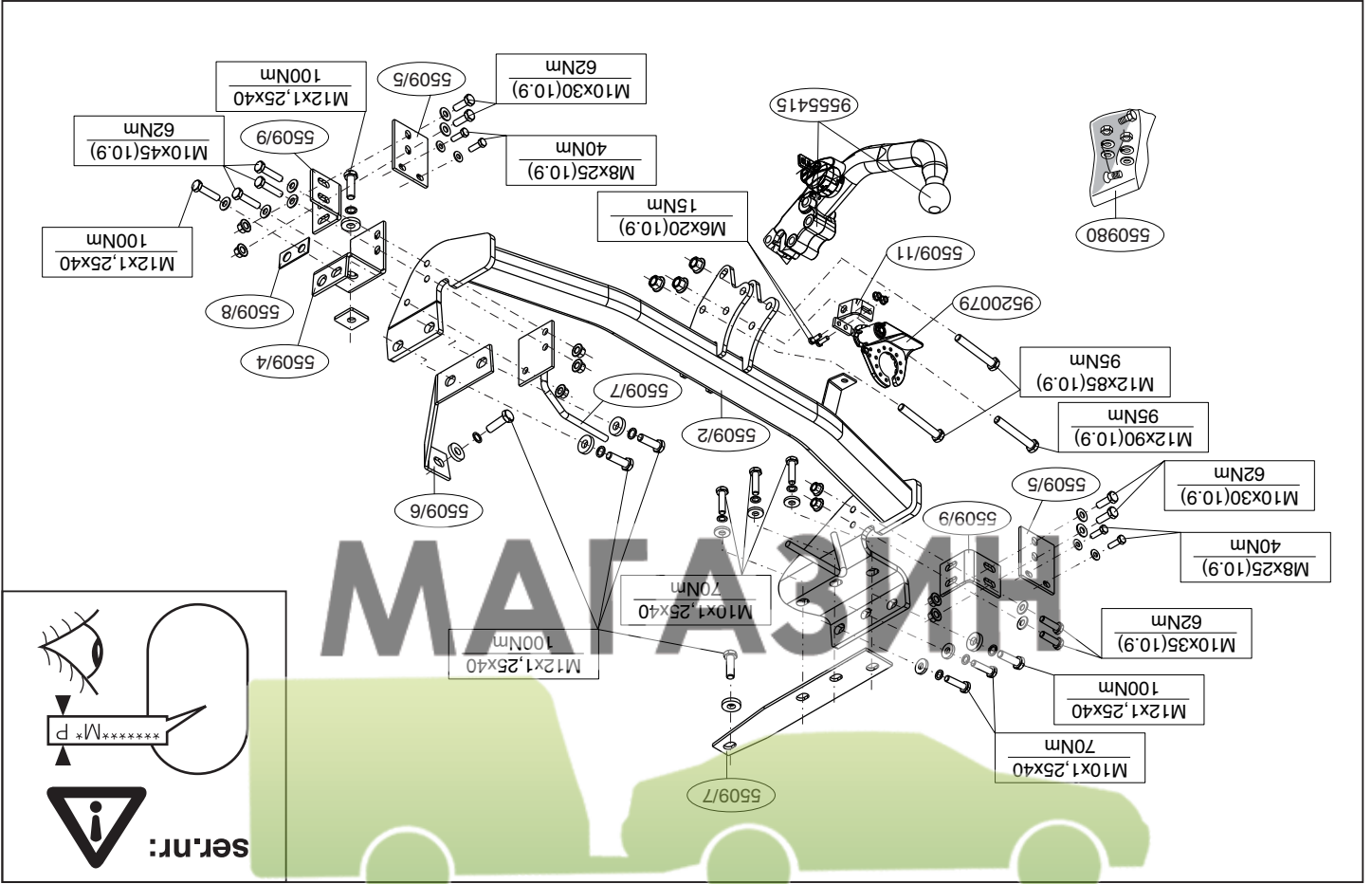

МАГФАРКОП

ФАРКОПОВ

+7 (495) 9-693-693

www.magfarkop.ru
magfarkop@yandex.ru



ФАРКОПОВ

+7 (495) 6-693-693

www.magfarkop.ru
magfarkop@yandex.ru

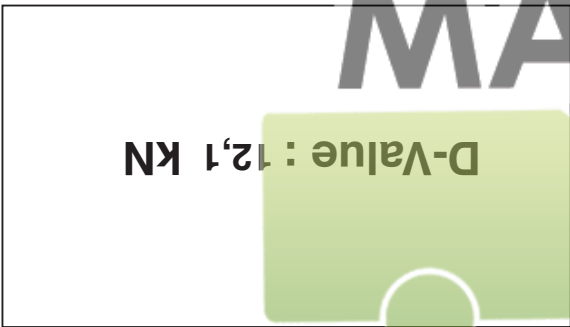
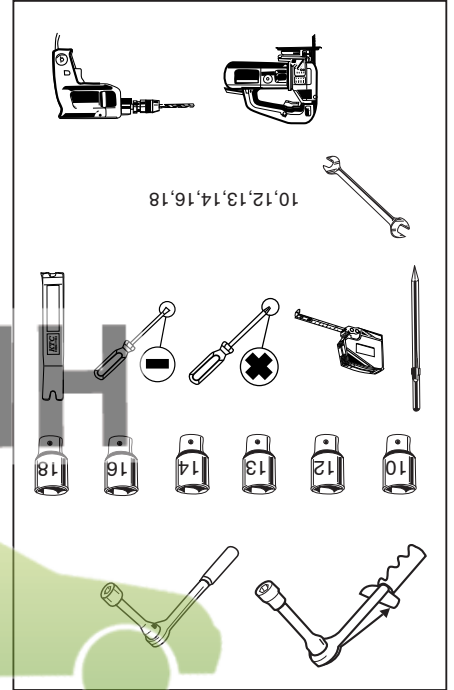
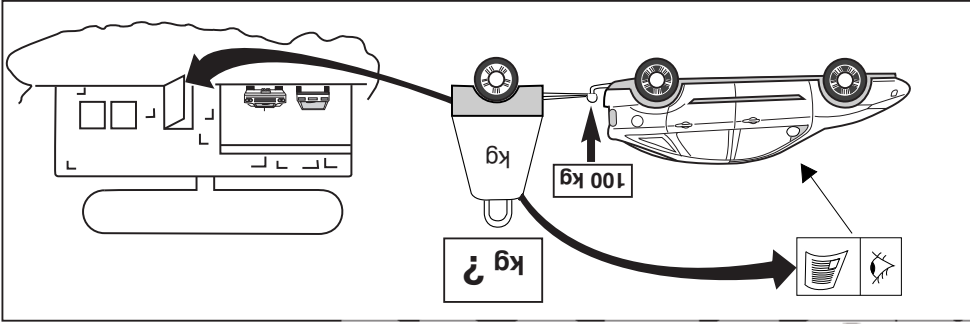
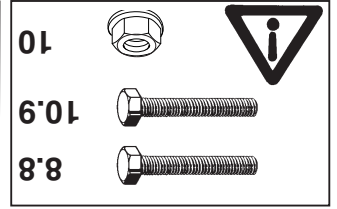
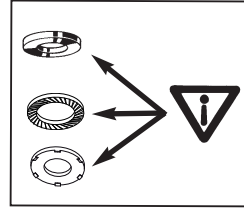
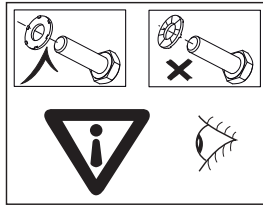
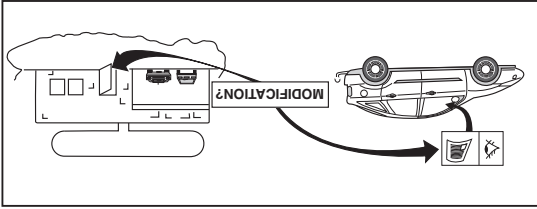

МАГАЗИН ФАРКОПОВ

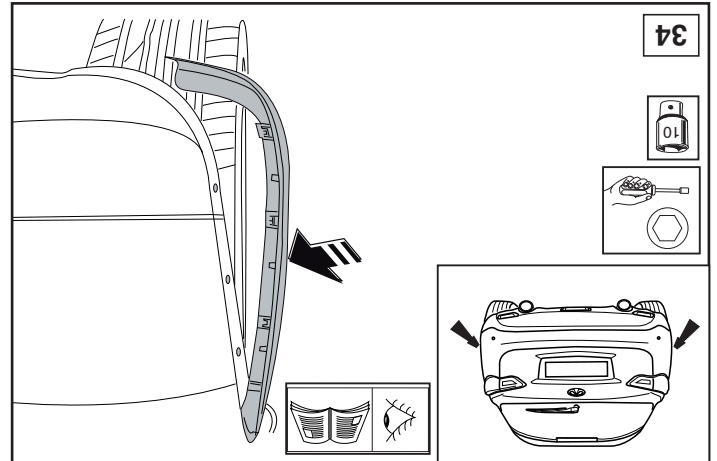
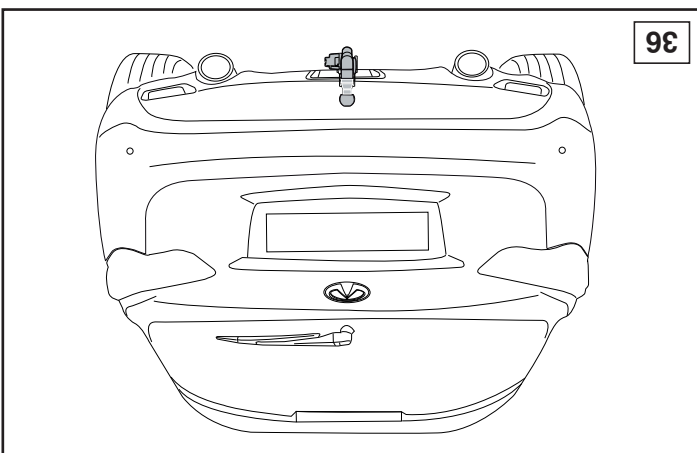
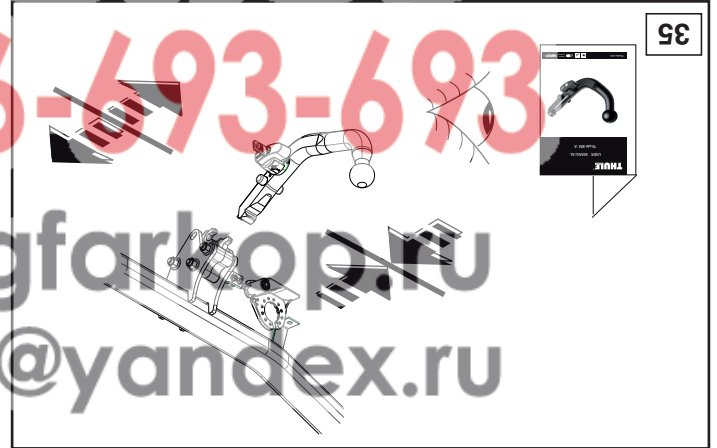
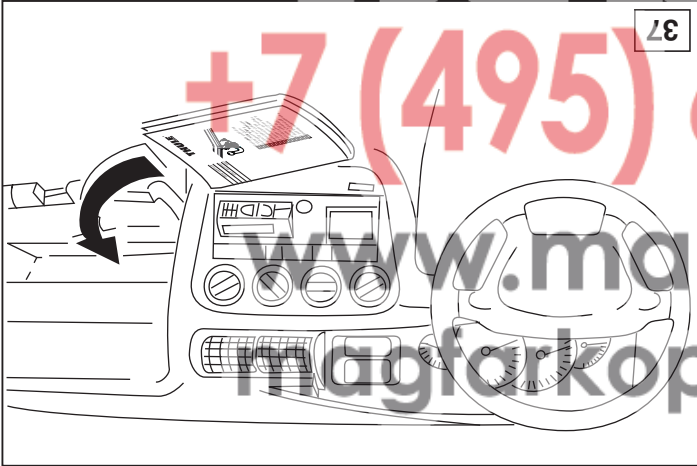

+7 (495) 6-693-693
www.magfarkop.ru
magfarkop@yandex.ru



NL.

* Thule is niet aansprakelijk voor de schade die het direct of indirect gevolg is van onjuiste montage, daaronder begrepen gebruik van niet-geschiedte gereedschappen en het gebruik van andere dan de voorgeschreven montagewijze en middelen, dan wel onjuiste interpretatie van dit onderhavig montagevoorschrift.

GB.

NOTE:

* **Should this installation process entail the cutting of the bumper – conformation MUST be obtained by the installation engineer of the customer’s acceptance prior to completion. Thule Towing Systems do not accept responsibility for any matters arising as a result of this miscommunication.**

All measurements are in mm!

* Thule is not liable for damage caused directly or indirectly by incorrect assembly, including the use of unsuitable tools, the use of other assembly methods and means than the ones outlined, and the incorrect interpretation of these assembly instructions.

D.

HINWEISE:

* Die für das Fahrzeug zugelassene Anhängelast ist den Fahrzeug Unterlagen zu entnehmen. Bei Änderungen des Fahrzeuggewichtes muß die höchstzulässige Anhängelast gegebenenfalls aus dem D-Wert nachgerechnet werden.

Auskunft hierüber kann Ihr Fachhändler oder der TÜV geben.

* Elektrische Anlage gemäß StVZO anbringen.

* Thule haftet nicht für Schäden, die als direkte oder indirekte Folge einer nicht ordnungsgemäßen Montage auftreten, darunter fallen auch die Benutzung von ungeeigneten Werkzeugen, andere als die vorgeschriebenen Montageverfahren und Montagemittel sowie eine fehlerhafte Interpretation der betreffenden Montageanweisung.

F.

* Thule décline toute responsabilité pour les dommages qui pourraient directement ou indirectement résulter d’un montage incorrect, y compris l’utilisation d’outils inappropriés et l’utilisation d’un mode d’emploi et de moyens autres que ceux prescrits, ou bien résulter d’une interprétation inexacte des présentes instructions de montage.

S.

* Thule är inte ansvariga för skada som orsakats direkt eller indirekt av felaktig montering, inklusive användning av olämpliga verktyg, andra monteringsmetoder och processer än de som beskrivs, samt felaktig tolkning av dessa monteringsinstruktioner.

DK.

* Thule er ikke ansvarlig for skade der direkte eller indirekte er forårsaget af forkert montage, herunder også iberegnet brug af forkert værktøj og anvendelse af anden montage metode og andre montage midler end de foreskrevne samt fejltolkning af den medfølgende montagevejledning.

E.

* Thule no se responsabiliza por daños causados, directa o indirectamente, por un montaje incorrecto, incluyendo el uso de herramientas inadecuadas, por el uso de métodos de montaje y medios distintos a los indicados y por la interpretación incorrecta de estas instrucciones de montaje.

I.

* Thule non può essere ritenuta responsabile per eventuali danni direttamente o indirettamente dovuti ad un errato montaggio, intendendo con ciò anche l’uso di attrezzi non idonei e l’uso di metodi e mezzi di montaggio diversi da quelli prescritti, nonché all’errata interpretazione delle seguenti istruzioni di montaggio.

PL.

* Firma Thule nie ponosi odpowiedzialności za straty poniesione pośrednio lub bezpośrednio na skutek niewłaściwego montażu, w tym użycia

© 550970/02-02-2012/5

МАГАСИЛ

ФАРКОПОВ

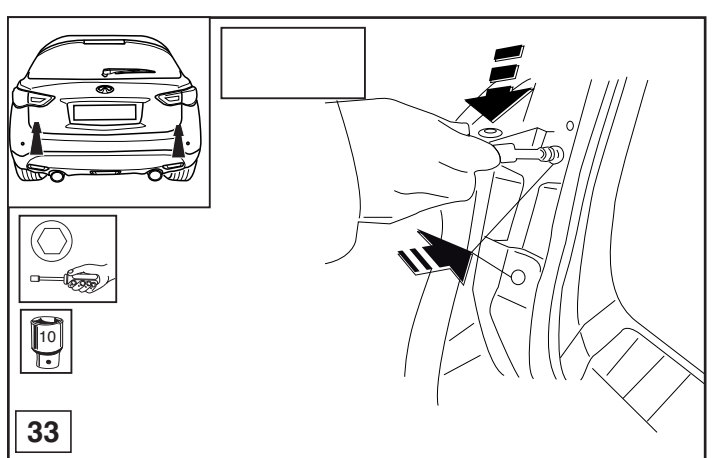
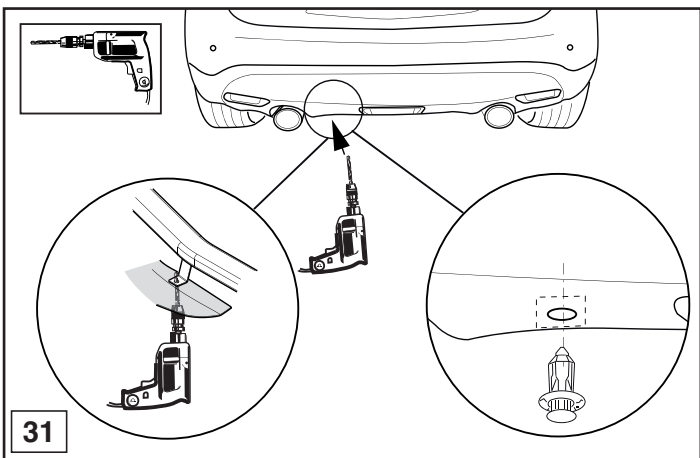
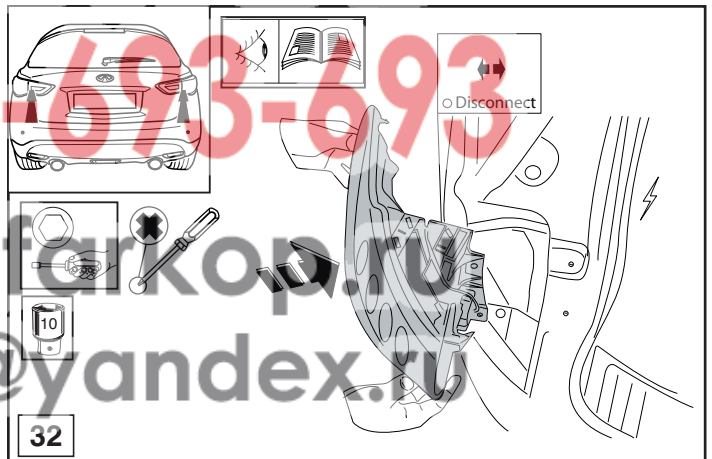

© 550970/02-02-2012/14

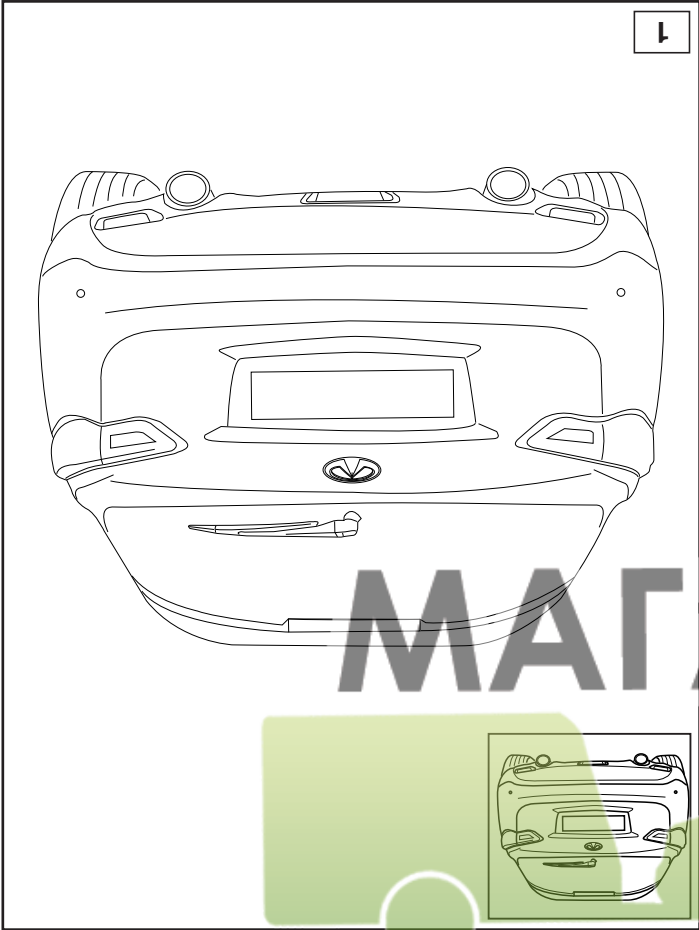

niewłasnych narzędzi i sposobów montażu niezgodnych z instrukcją, oraz niezastosowanie się do treści instrukcji.

SF: * Thule ei ole vastuissa violitumisesta, joka on suoraan tai epäsuoraan aiheutunut vääristystä asennuksesta samoin kuin sopimattomien työkalujen käyttöä, muiden kuin ohjeissa mainittujen asennusmenetelmien tai välineiden käyttöä sekä kyseisten asennusohjeiden väärinkäytämistä.

CZ: * Společnost Thule neodpovídá za přímé ani nepřímé škody způsobené nesprávnou montáží, včetně použití nevhodných nástrojů, použití jiných metod montáže a prostředků než uvedených a nesprávným pochopením techniky montáže.

H: * A Thule nem vállal felelősséget a nem megfelelő szerelésből közvetlen vagy közvetett módon következő károkat. Ez vonatkozik a nem megfelelő szerzők alkalmazására, valamint a szerelési útmutató téves értelmezésére.

RUS: * Фирма Thule не отвечает за ущерб, являющийся прямым или косвенным следствием неправильного монтажа, в том числе использование неподходящих инструментов и применение иного способа монтажа или других средств, чем предписано в инструкции, либо неправильного истолкования настоящей инструкции или по монтажу.

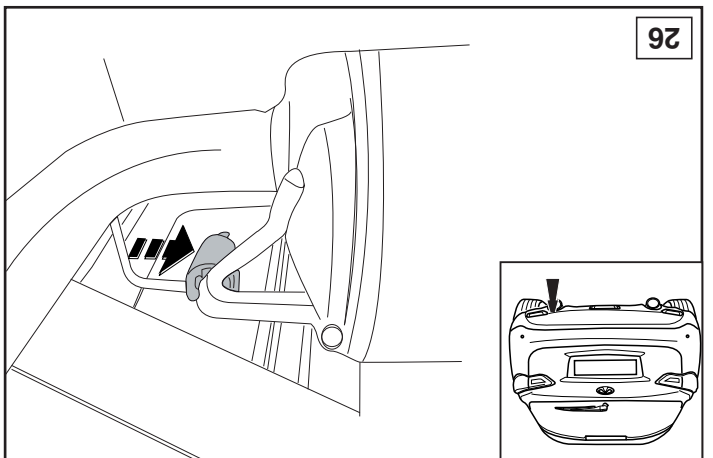
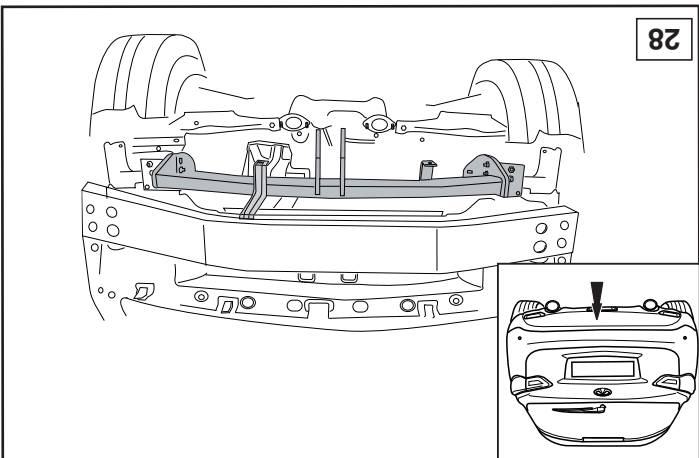
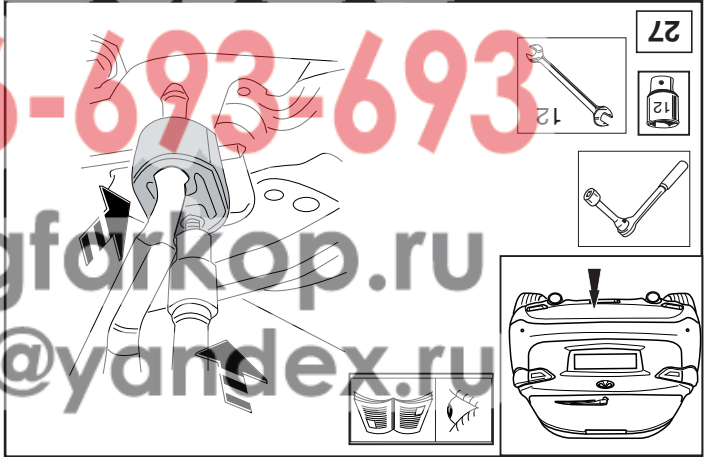
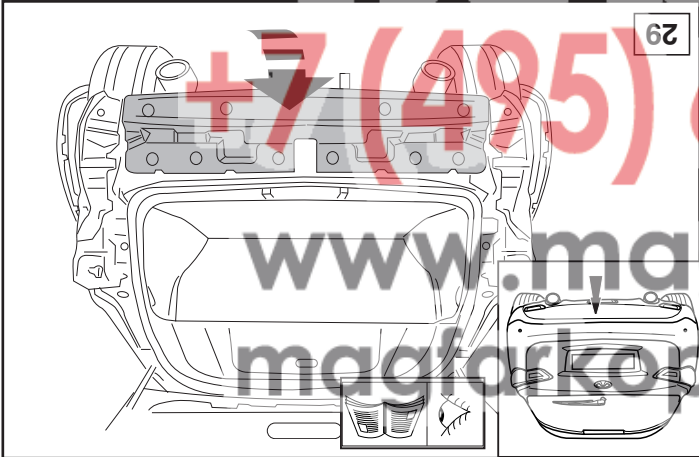

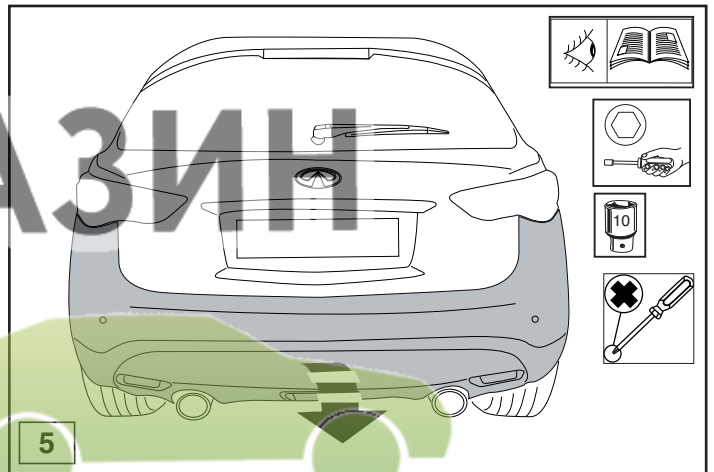
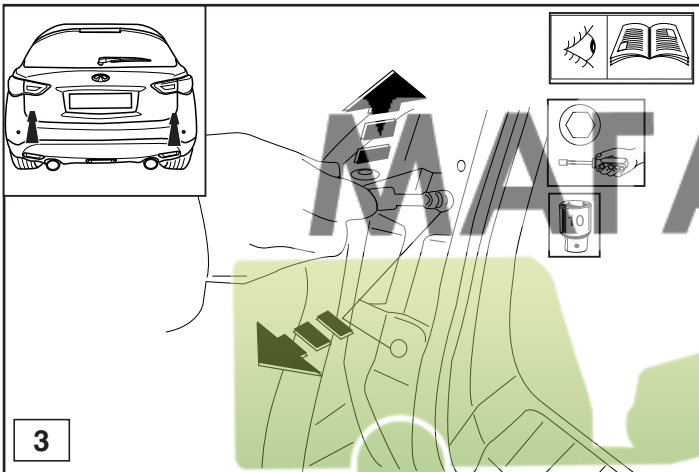
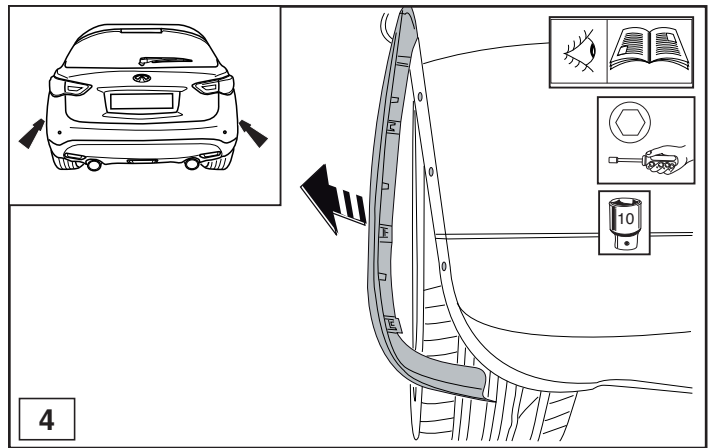
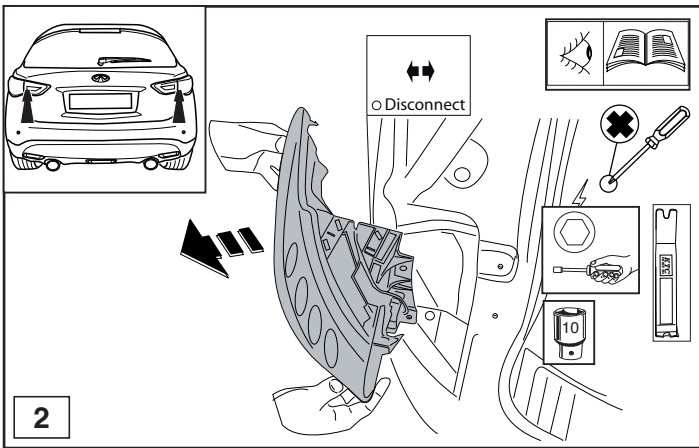

© 550970/02-02-2012/7

МАГАЗИН ФАРКОПОВ

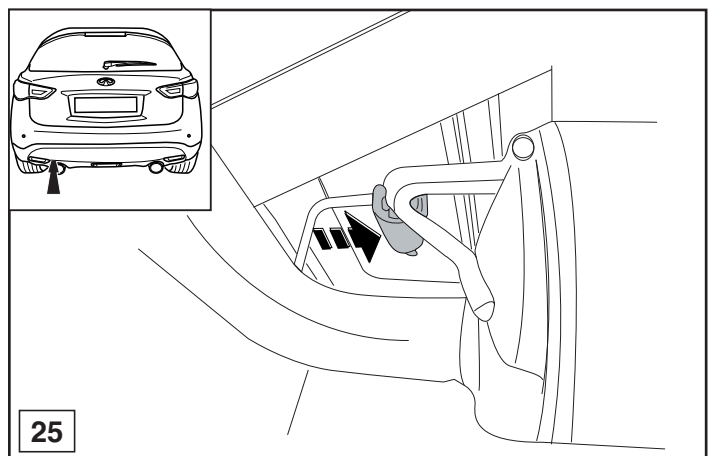
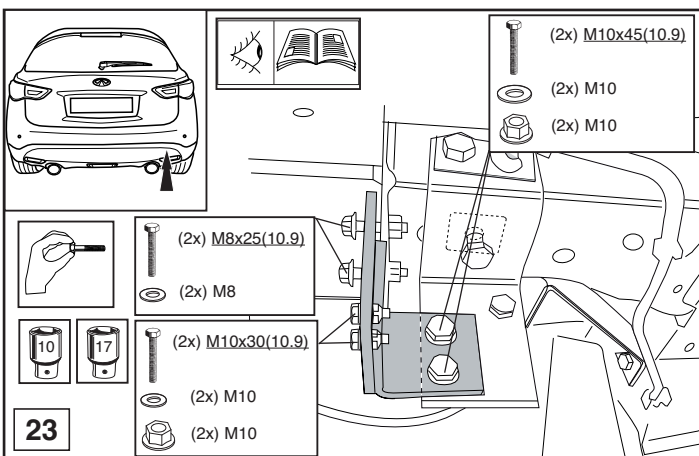
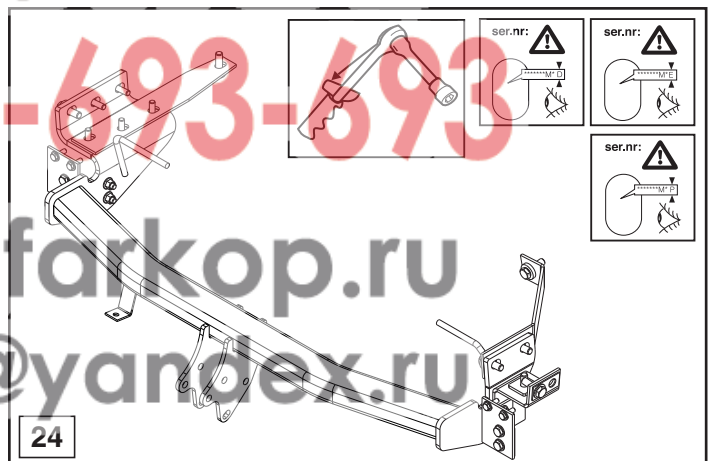
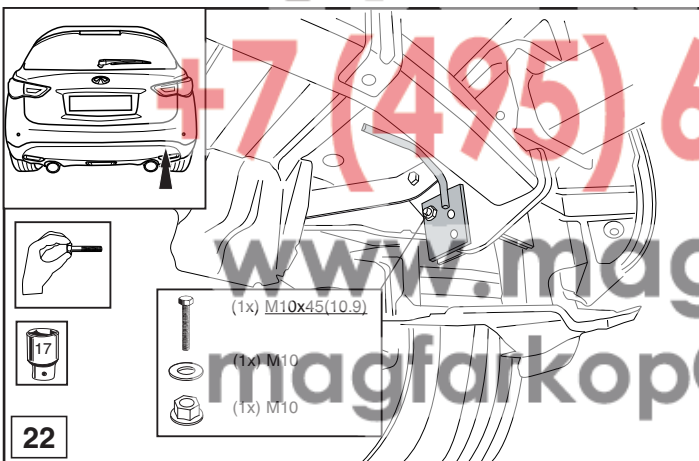

© 550970/02-02-2012/12

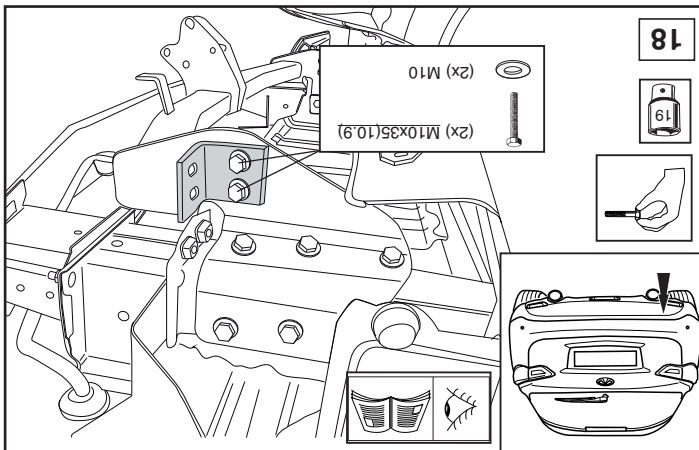
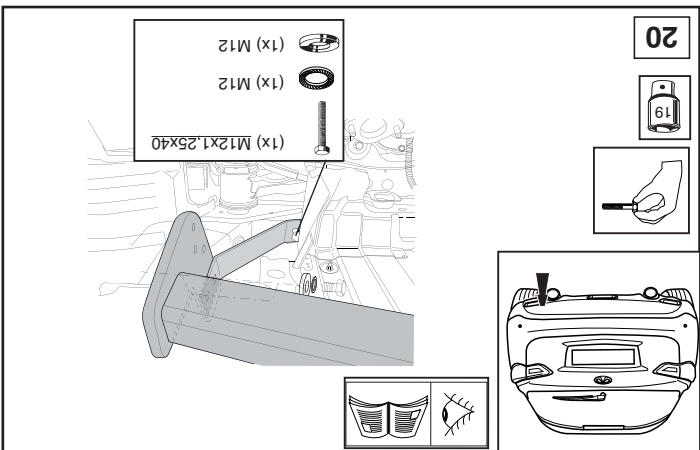
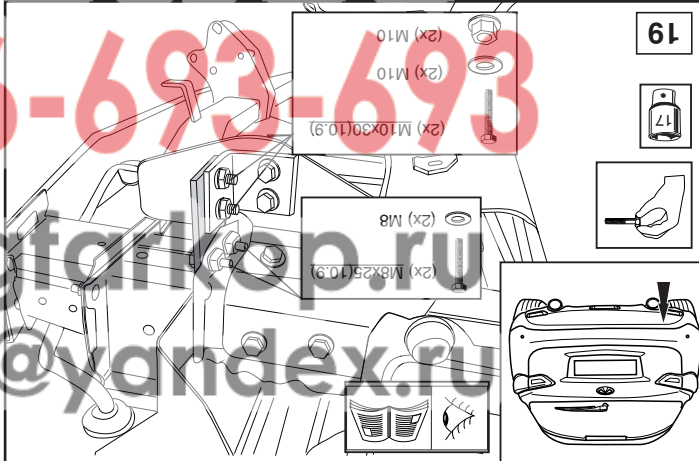
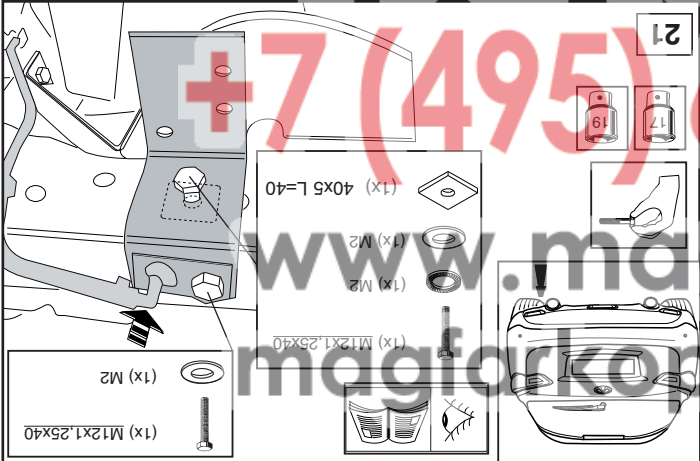
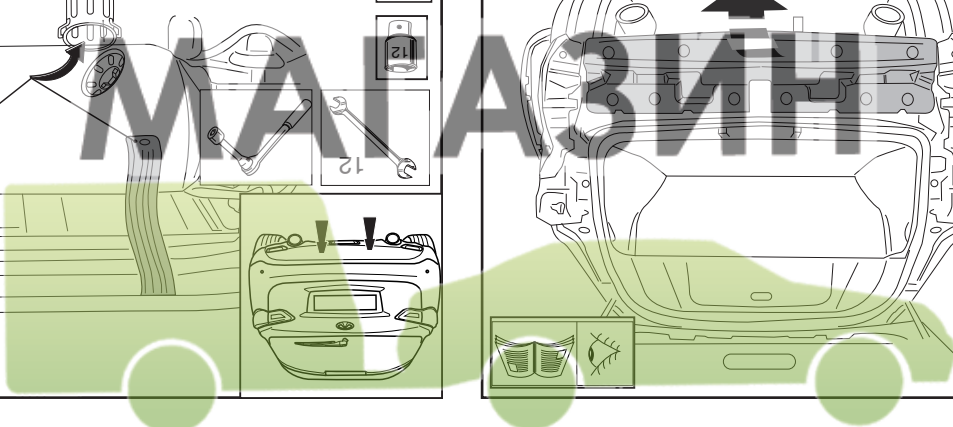
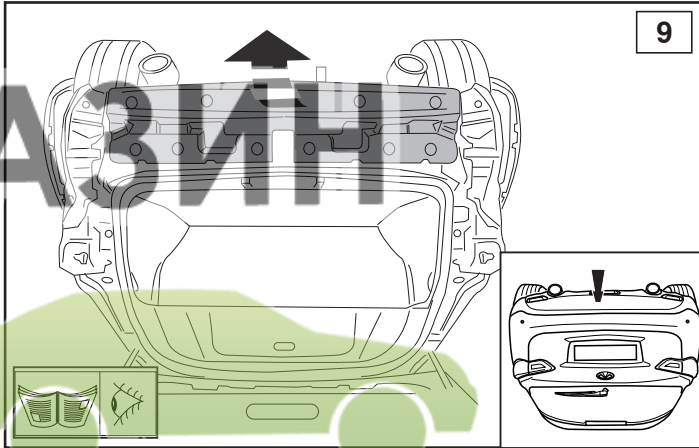
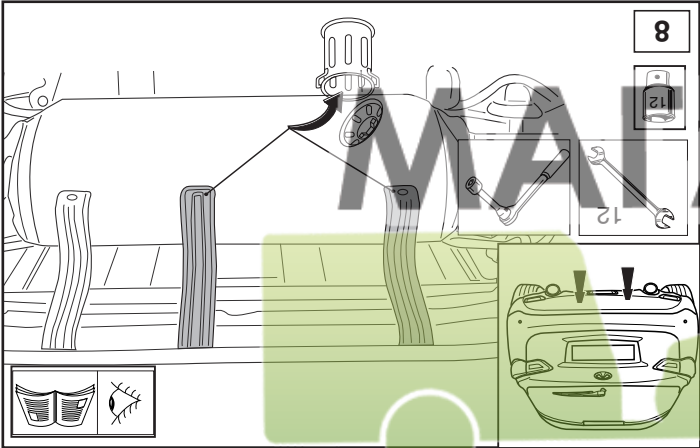
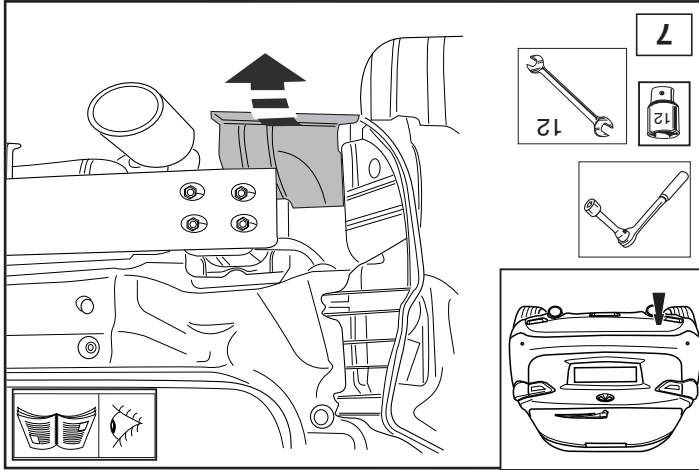
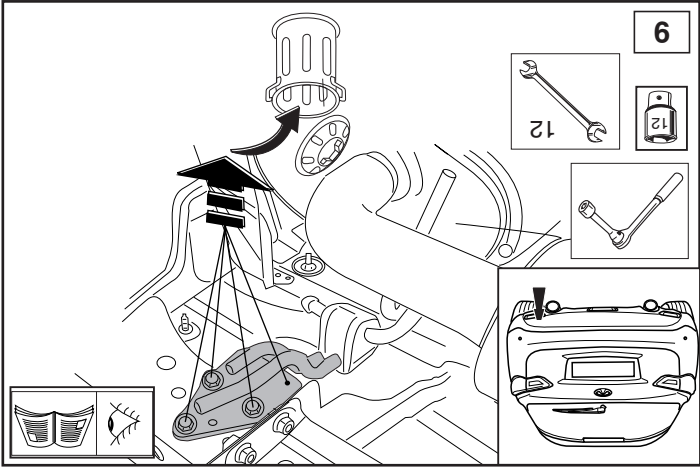

+7 (495) 6-93-693

www.magfarkop.ru

magfarkop@yandex.ru

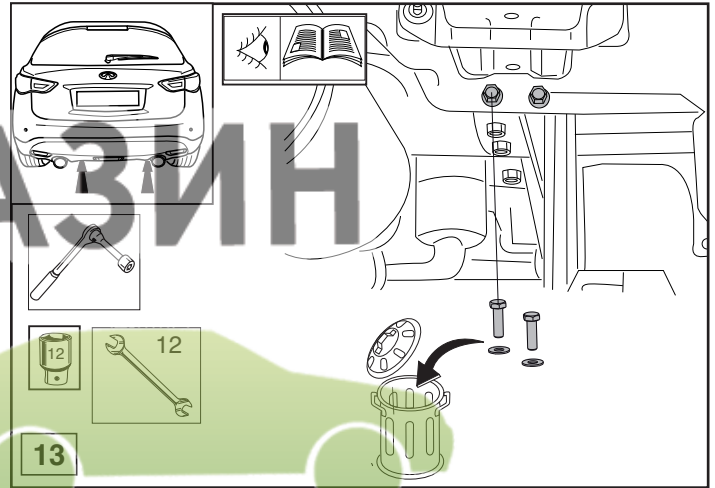
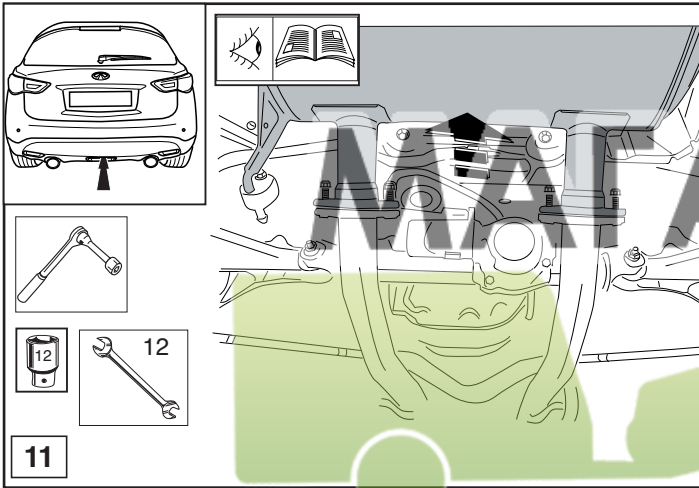
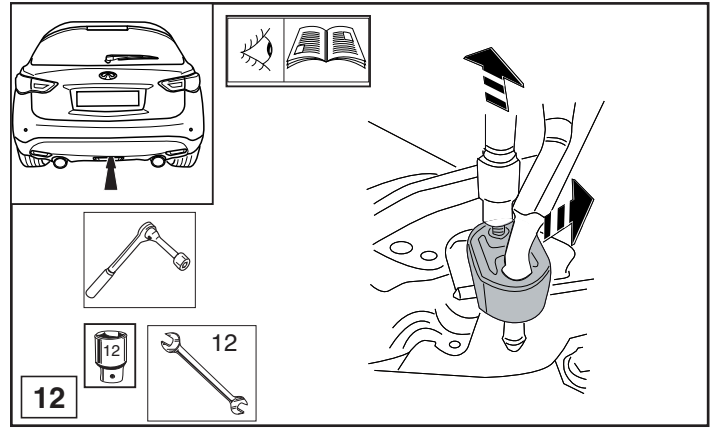
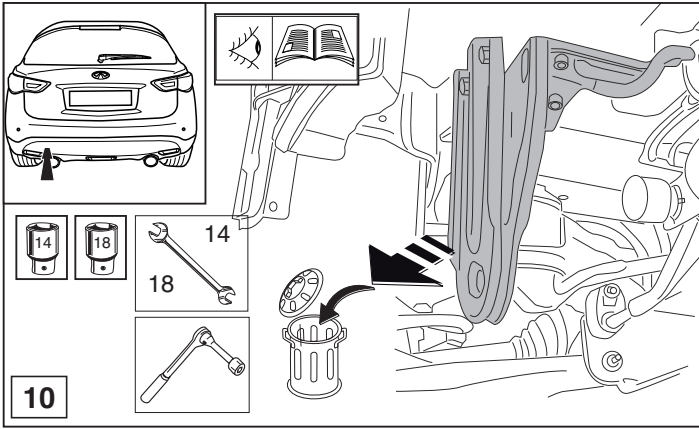

© 550970/02-02-2012/9

МАГ АЗМН

ФАРКОПОВ

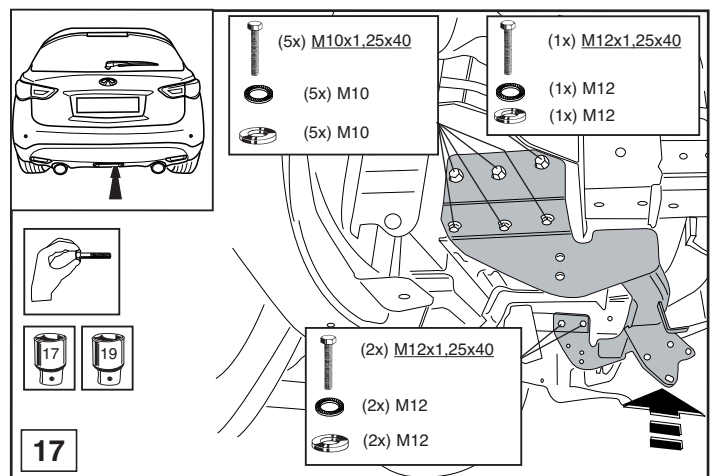
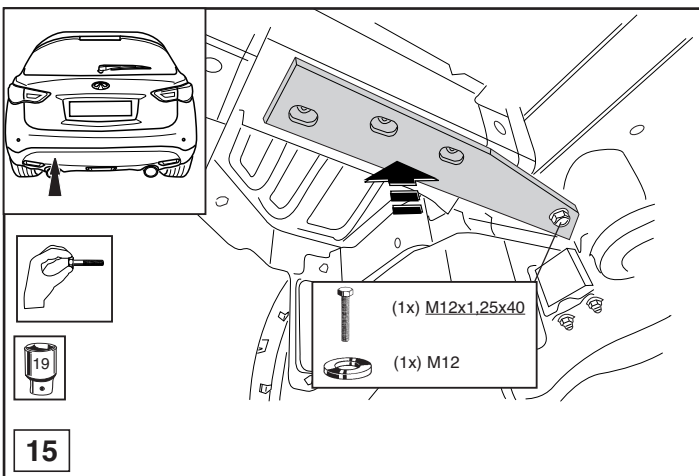
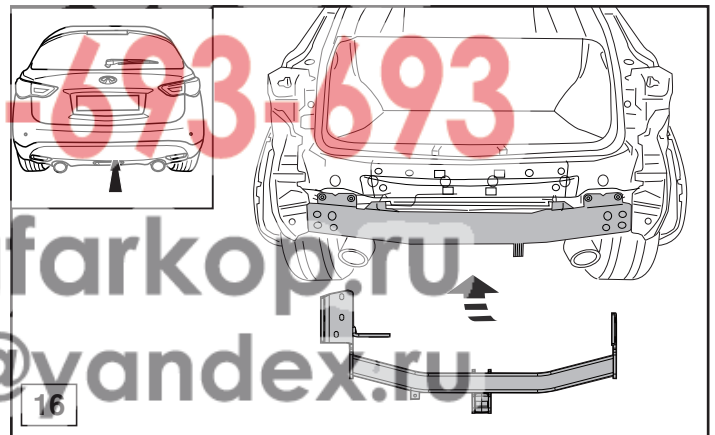
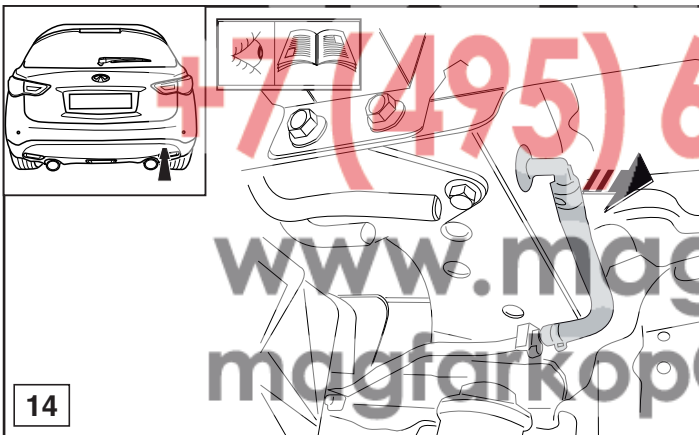

© 550970/02-02-2012/10

+7 (495) 6-693-693
www.magfarkop.ru
magfarkop@yandex.ru

МАГАЗИН



ФАРКОПОВ

+7 (495) 6-693-693

www.magfarkop.ru

magfarkop@yandex.ru

Template 5509

Place on outside bumper

