

# bosal

# МАГАЗИН

**Инструкция по монтажу  
тягово-цепного устройства  
шарового типа 5518 А  
для автомобилей  
Honda CR-V**



# ФАРКОПОВ

# +7 (495) 6-693-693

[www.magfarkop.ru](http://www.magfarkop.ru)  
[magfarkop@yandex.ru](mailto:magfarkop@yandex.ru)



462800,

« - »

18

т. (35363) 7-05-06  
ф. (35363) 7-13-20  
(495) 785-66-07  
[www.bosal-autoflex.ru](http://www.bosal-autoflex.ru)

	2002—2007.
	1400
	50
	26,6

« - »	(8182) 22-48-15
"	8(8442) 98-74-98
"	8(343) 379-39-89, 373-42-73
"	8(343) 26-88-308
"	8(3952) 710-194
"	8(495) 777-54-59
"	8(495) 745-79-11
"	8(495) 788-95-97
"	8(495) 720-51-03
"	8(3532) 57-99-85
"	8-905-899-5012
"	8(383) 291-59-60
"	8(831) 279-53-24
"	8(3422) 98-27-20
"	8(342) 220-87-87
"	8-927-002-90-06
"	8(3462) 24-00-44
"	8(3842) 21-14-76
"	8-902-940-4151
"	8(3452) 32-22-12, 41-52-62
"	8-961-213-0278
"	8-917-347-1700
"	8(351) 269-44-75, 900-72-73
"	8(3512) 773-76-91

41.55-2005.

Ø11

( 4, 5 ).

«6»  
«b»

6 30.

12 40.

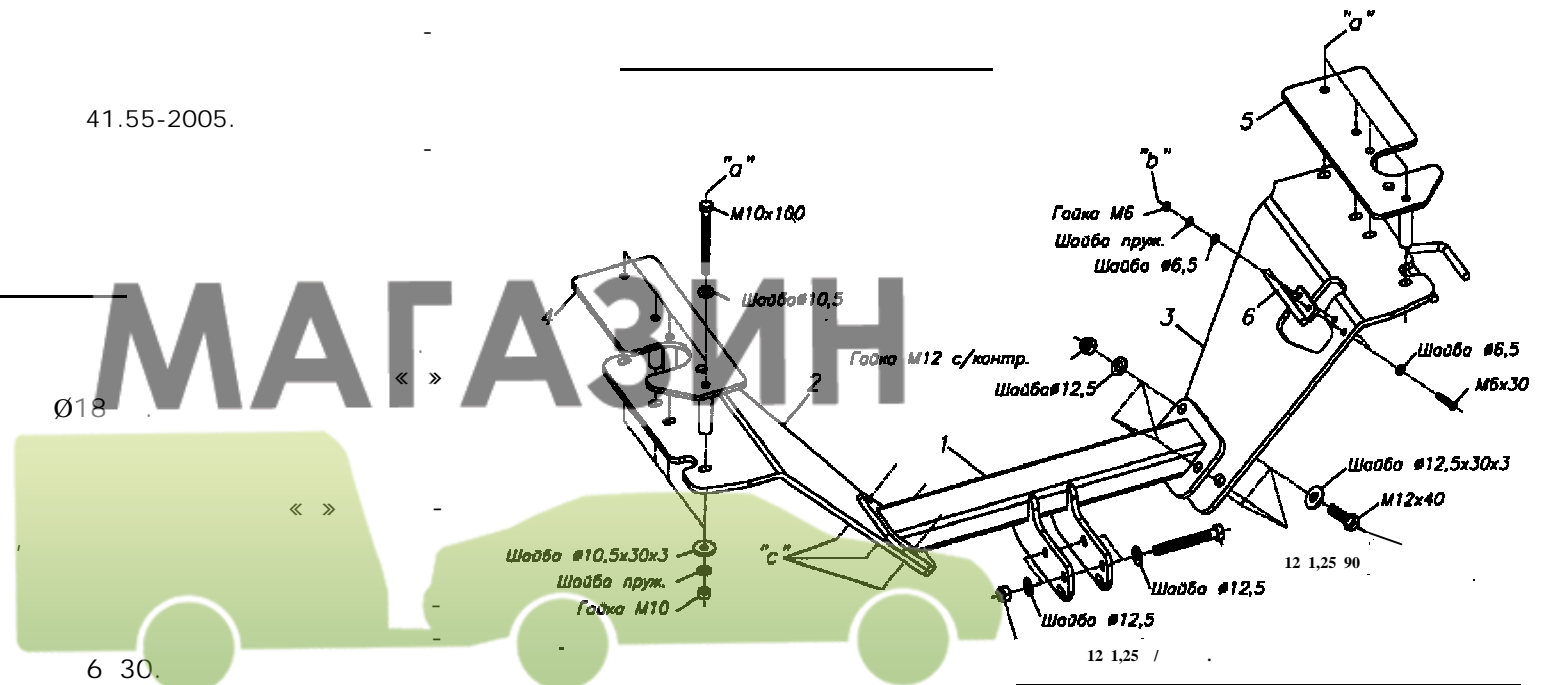

# ФАРКОПОВ

+7 (495) 6-693-693

www.magfarkop.ru  
magfarkop@yandex.ru

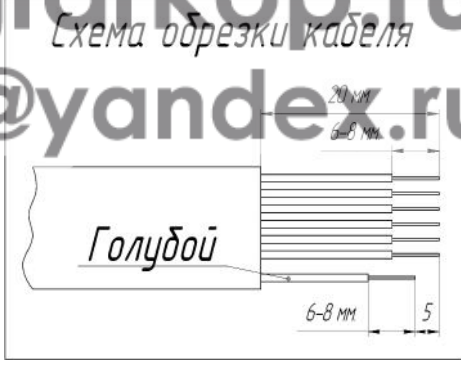
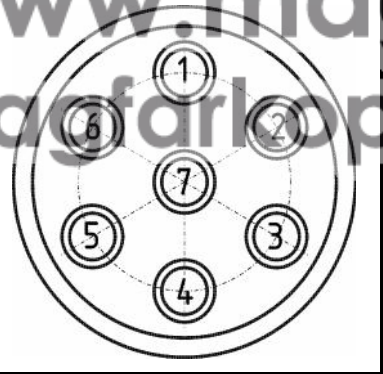

1		
2		
3		
4		
5		
6		
7		

6	2
10	8
12 1,25 /	2
12 /	6
6	4
6 ( . )	2
10	8
10 ( . )	8
10 ( . )	8
12	6
12 ( . )	6
( . 6)	1
	2
VH 0181	1
	1
	1
	1
190	1
	1
	3
6 30	2
10 100	8
12 40	6
12 1,25 90	2