

(C203-A) CHEVROLET LACETTI () 2004-...		D (H)	S ()	T ()	C ()
	C203-A	5,4	75	1200	1000
D = g* TC/T+C					
S-					
T-					
C-					

(C203-A) CHEVROLET LACETTI () 2004-...
1000

80 /

28248-89 «
37.001.096-93 “

МАГАЗИН



	(C203-A) CHEVROLET LACETTI () 2004-...	1
	...	1
50		1
16		1
		1

3.

!

ФАРКОПОВ

+7 (495) 6-693-693

1.
www.magfarkop.ru
magfarkop@yandex.ru

4.

(12) 2 Ø 12.5 10 95 1.25
12 (20)
(16), (2) (14), 10 115 1.25,
10 1.25

()

203-

1	6 35		2
2	10 1.25 115		2
3	12 40		4
4	12 70		2
5	12 120		4
6	10 1.25		2
7	12		8
8	d10		2
9	d12		2
10	d10		2
11	d12		11
12	1	8	2
13	2	6	2
14	3	4	2
15			1
16			1
17			1
18			1
19	L-8		1
20	L-72		4

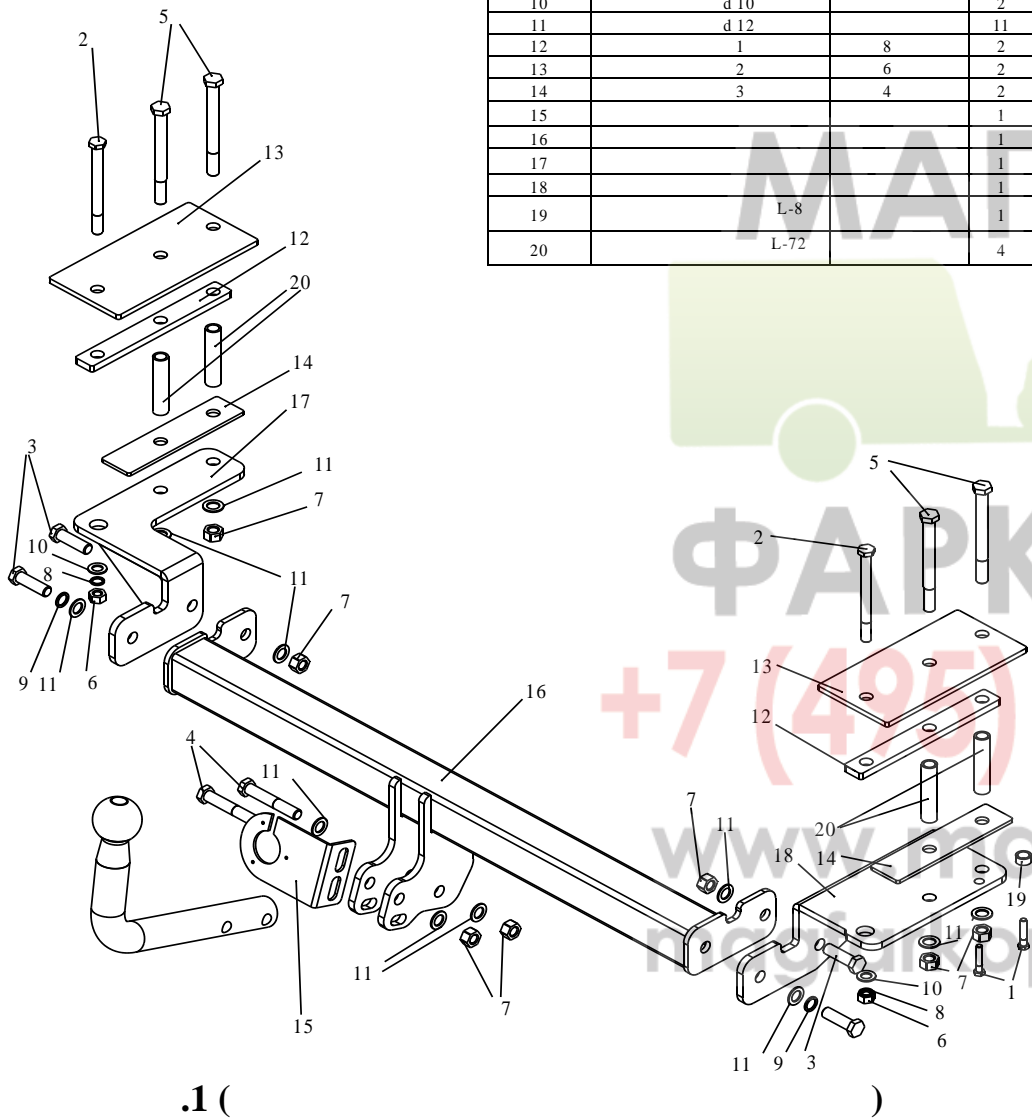

МАГАЗИН



ФАРКОПОВ

+7 (495) 6-693-693

www.magfarkop.ru
magfarkop@yandex.ru

.1 (

)