

(V113-A) Volkswagen Caddy 2004-...		D(H)	S()	T()	C()
V113-A		6,1	75	1700	1000
D = g* TC/T+C					
S-					
T-					
C-					

(V113-A) Volkswagen Caddy 2004-...
1000 , 80 / .
28248-89 «
37.001.096-93 “

МАГАЗИН

1.	2.	(V113-A) Volkswagen Caddy 2004-...	
			1
	50		1
	17		1
			1

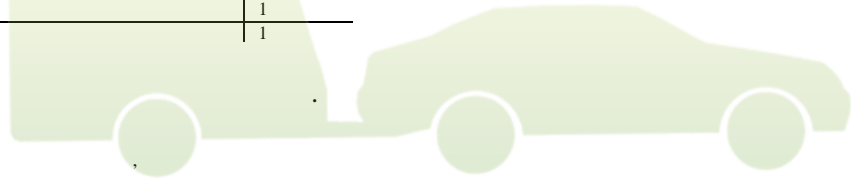

ФАРКОПОВ

+7 (495) 6-693-693

www.magfarkop.ru
magfarkop@yandex.ru

1 (L/1)	-	11
2 (54/2G)		2
3 (31/3)		8
4 (R/4)		3
5 (58R/5)		4
6 (54/6)		17
7 (58L/7)		4

1	12 40	
2	12 90	
3	12	
4	12 1.25	
5	d 12	
6	d 12	
7		
8		
9		
10		
11		
12		
13		

V 113-A

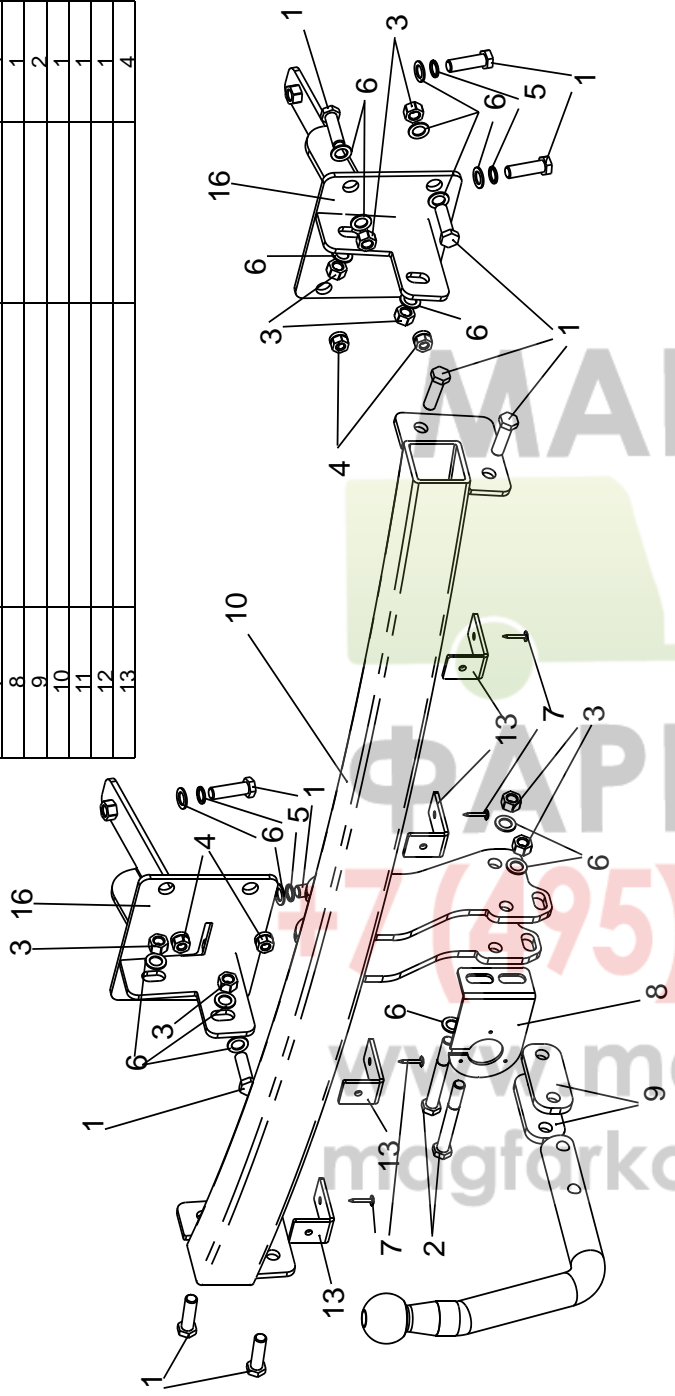

.1(

)

МАГАЗИН
 ФАРКОПОВ
 (495) 6-693-693
 www.magfarkop.ru
 magfarkop@yandex.ru